

## CW-NZ-0132

### 4G PCB Antenna

#### Key Features

Frequency: 698-960MHz/1710-2700MHz

I-PEX Connector

1.13 Cable

Dimensions 125\*14\*0.8mm



## 1. Antenna Electrical Characteristics

Band (MHz)	
Frequency (MHz)	698-960MHz/1710-2700MHz
VSWR	≤2.5
Efficiency (%)	88.4%/78.48%
Peak Gain (dBi)	3.35/3.56
Impedance (Ohm)	50
Polarisation	Vertical
Max. Input Power (W)	10
Connector Type	I-PEX

## 2. Material and environmental characteristics

External structure	N/A
Inner structure	Connector/Cable/PCB
Cable Type	RF1.13
Connector Type	I-PEX
Dimensions (mm)	125*14*0.8MM
Antenna color	N/A
Operation Temperature	-40 to +80
Storage Temperature	-40 to +80
Antenna Storage life(year)	10
Substance Compliance	ROHS

REV	Date	Description
X1	2022/10/05	New issue

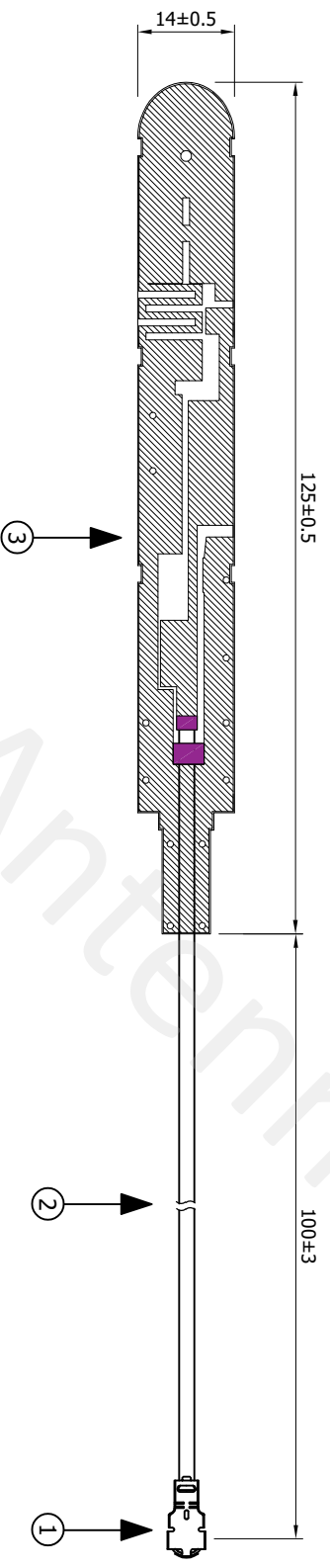

Specification(Free Test):  
 Frequency Range: 698-960MHZ/1710-2700MHZ  
 Impedance: 50Ω  
 V.S.W.R: ≤ 2.5  
 100% Continuity,short and open circuit test  
 Materials,parts and process must by environmentally (ROHS)

4	Foam cotton	88*13*0.13MM	1		
3	PCB	125*14*0.8MM Green	1		
2	Cable	Ø1.13MM black double tin wire	1		
1	Connector	Ø1.13 I-PEX (equivalents)	1		
NO	Name	Description	Q'TY	Remark	
XX.	±5.0	Approved			
X.	±3.0				
.X	±1.0	Checked			
.XX	±0.2				
.XXX	±0.1	Drawing			
			REV	Unit	File
			X1	m/m	
				Sheet :	1/1



## 4. Antenna test parameters

### Antenna Measurement Conditions:

Mounted on Ground Plane of 280 x 80 mm

Measured in Certified 3D Anechoic Chamber

The network analyzer is Agilent 5071c

The comprehensive tester is Agilent cmv500

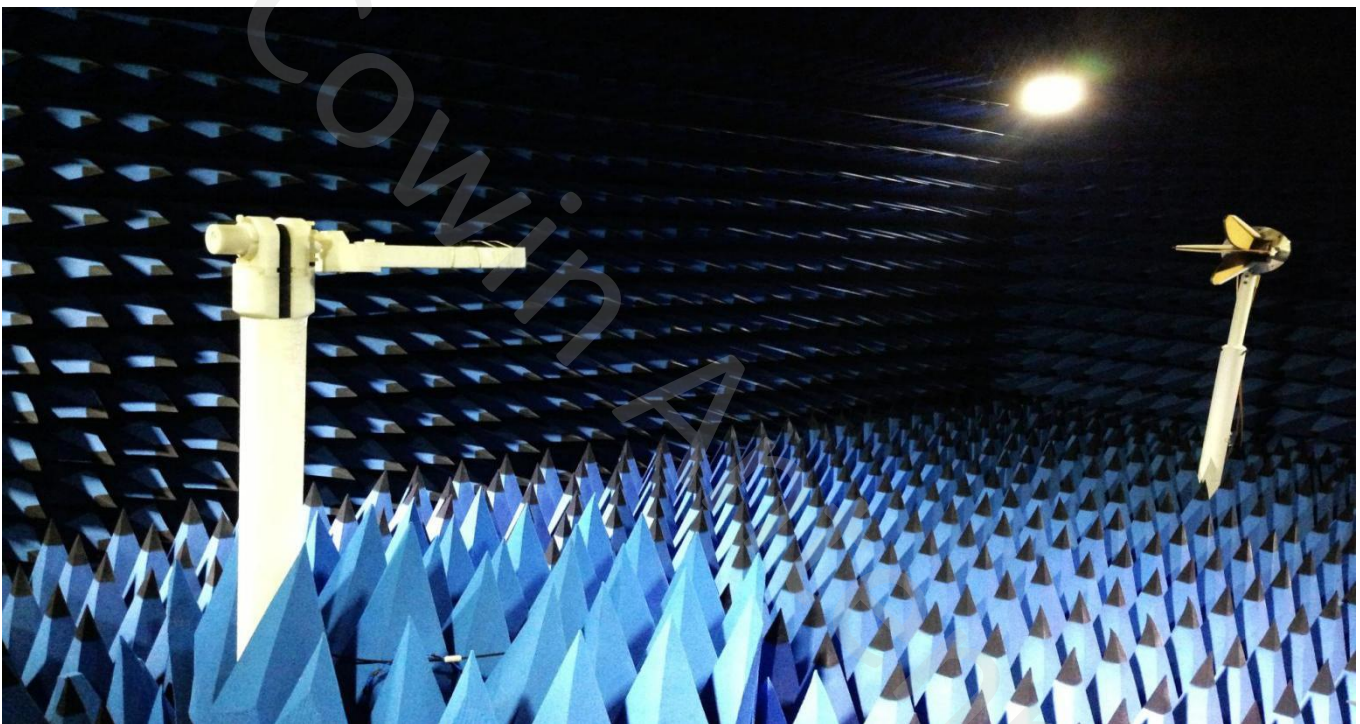

## 4.1 VSWR

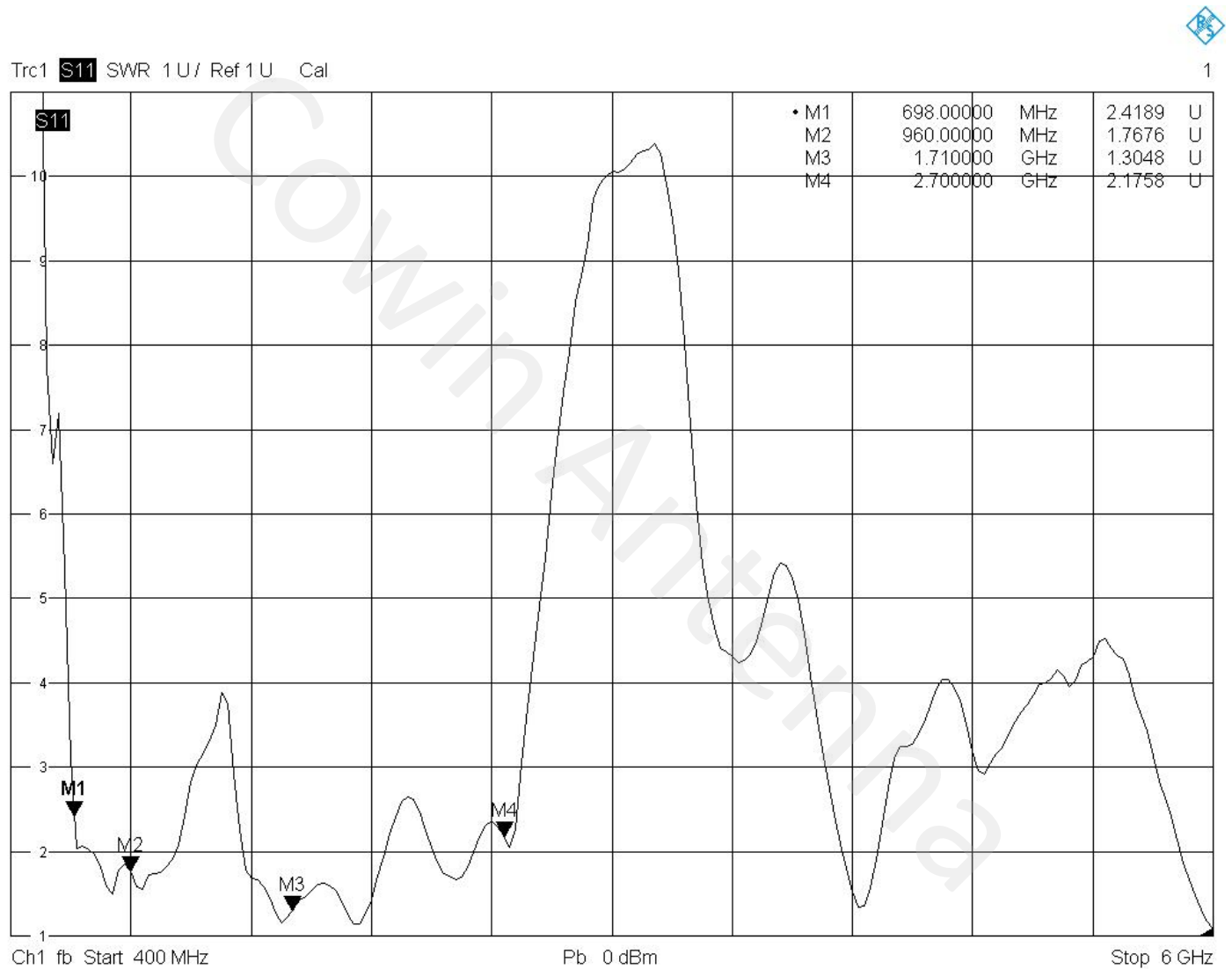

12/5/2022, 12:34 AM

## 4.2 Efficiency

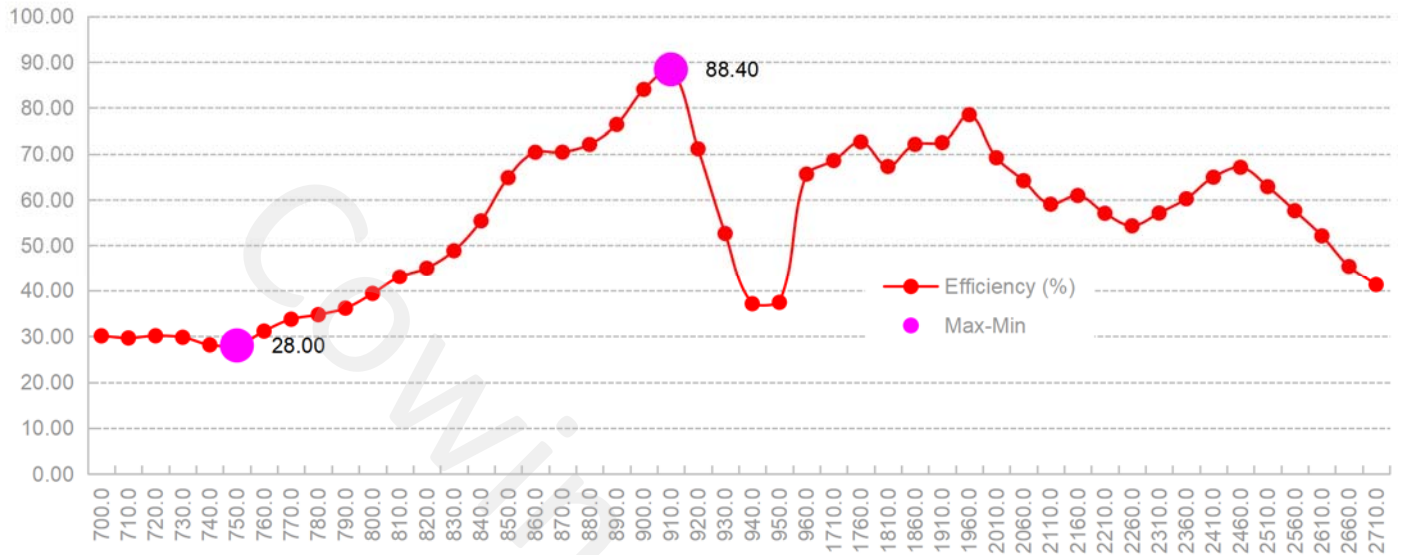

## 4.3 Peak gain

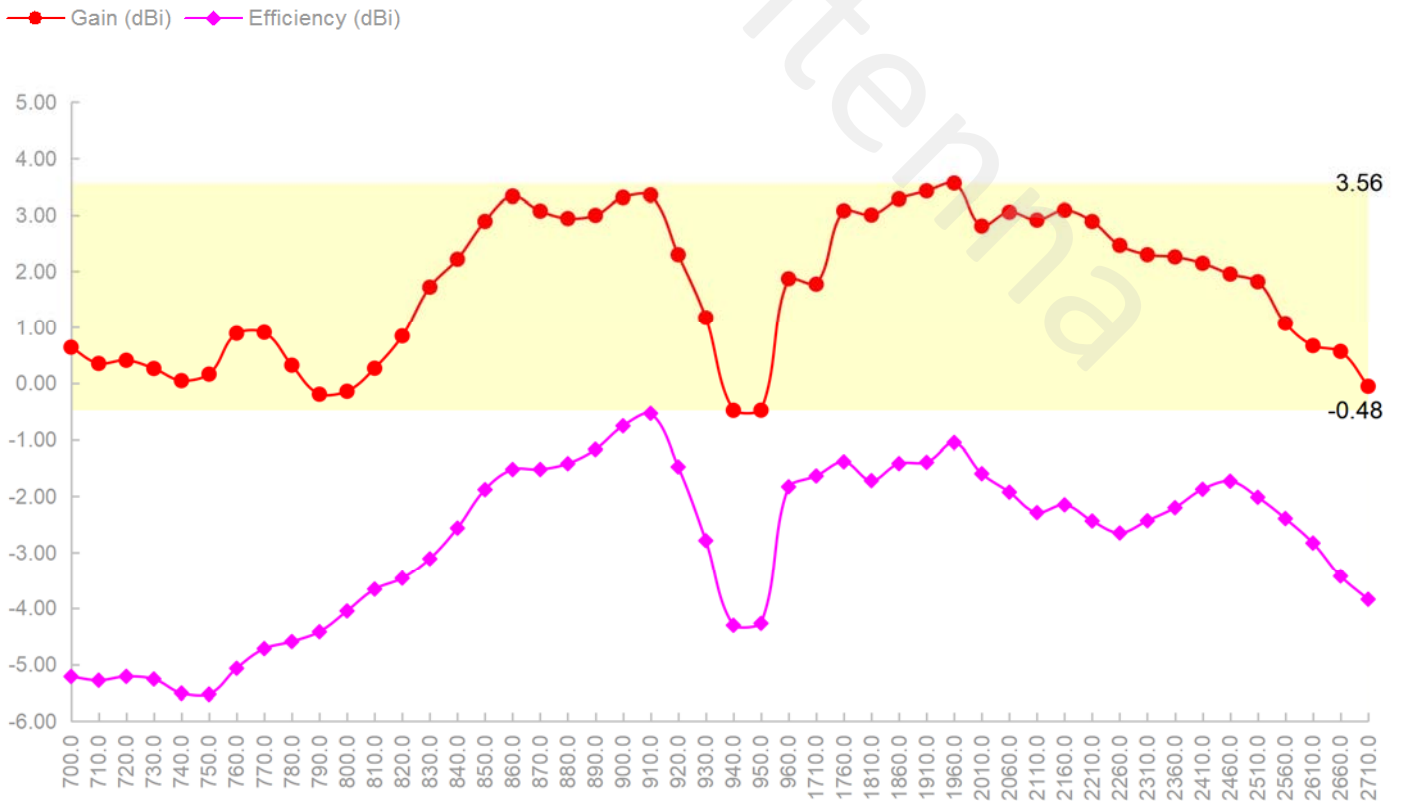

## 4.4 3D&2D Radiation Patterns

700.0MHz H+V, Eff: 30.1%

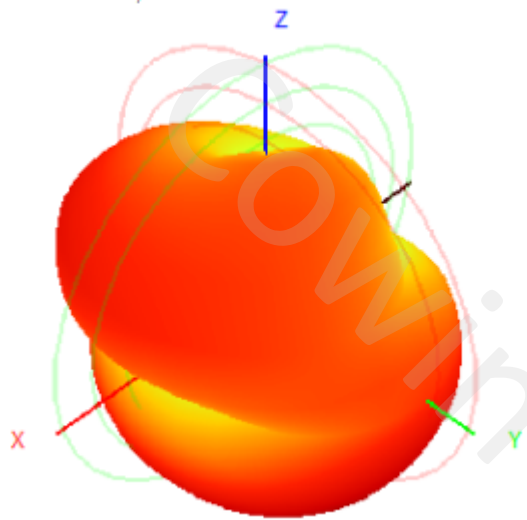

Back View

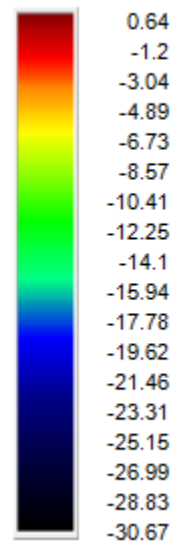
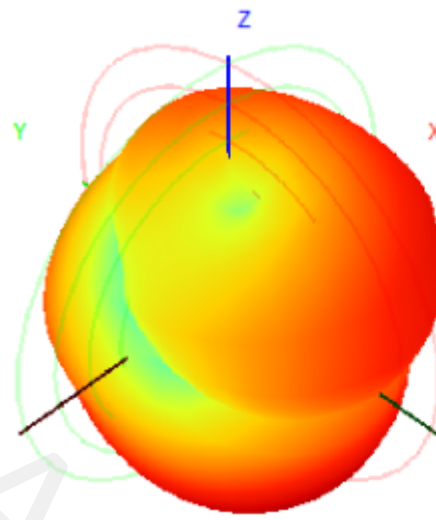

700.0MHz Total(E1-XZ), Max= -1.46dBi

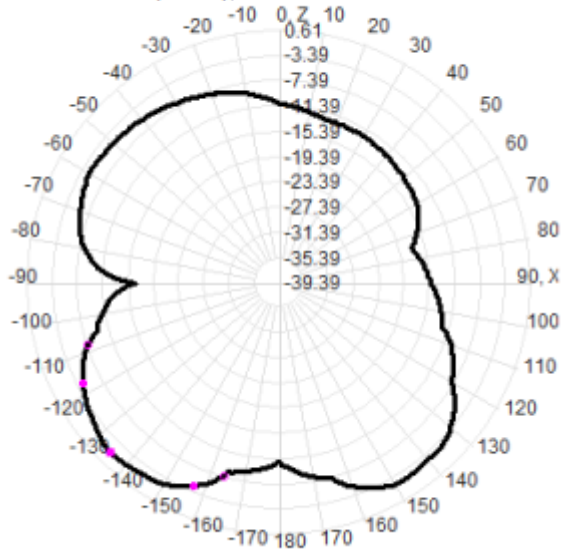

700.0MHz Total(E2-YZ), Max= 0.61 dBi

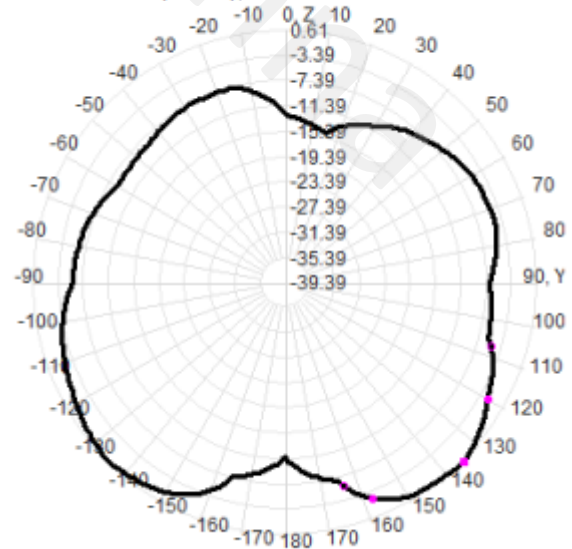

850.0MHz H+V, Eff: 64.9%

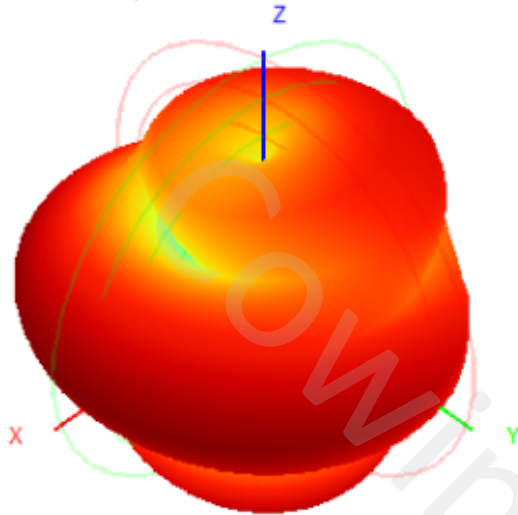

Back View

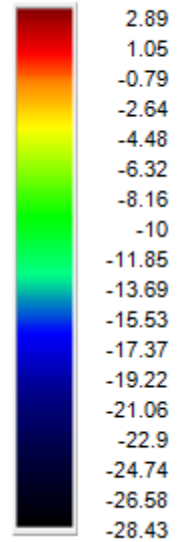
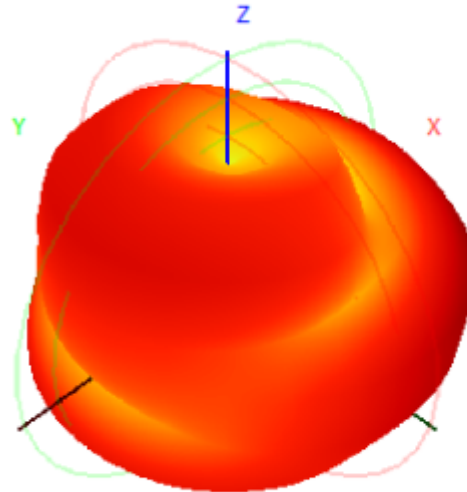

850.0MHz Total(E1-XZ), Max= 2.89dBi

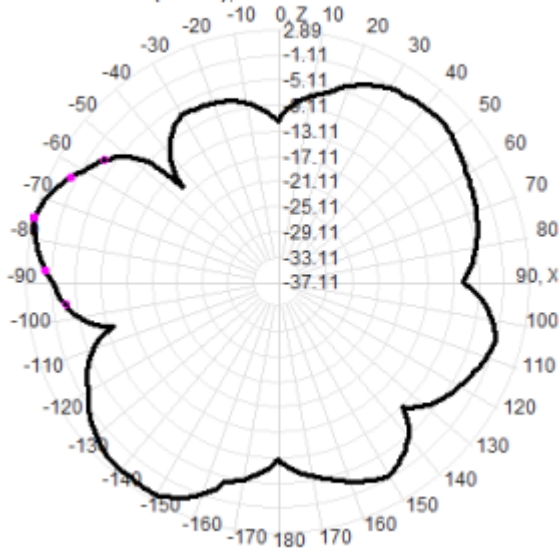

850.0MHz Total(E2-YZ), Max= 1.94dBi

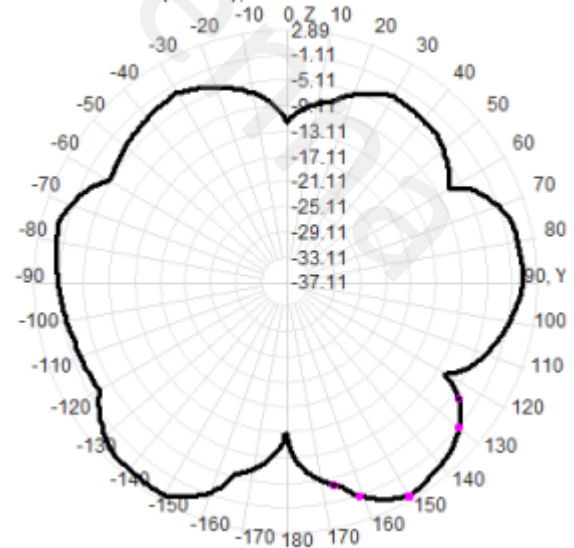



960.0MHz H+V, Eff: 65.6%

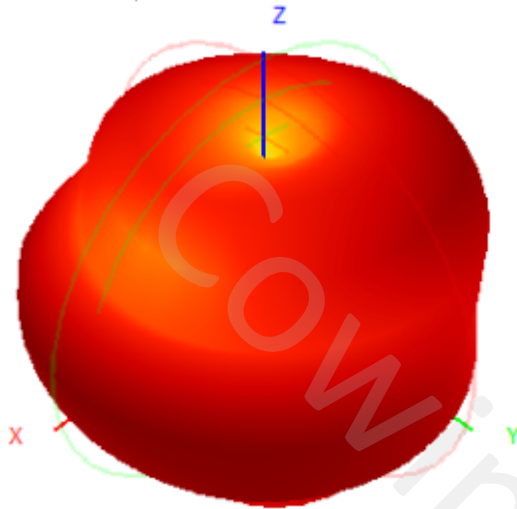

Back View

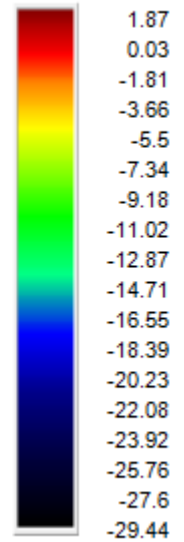
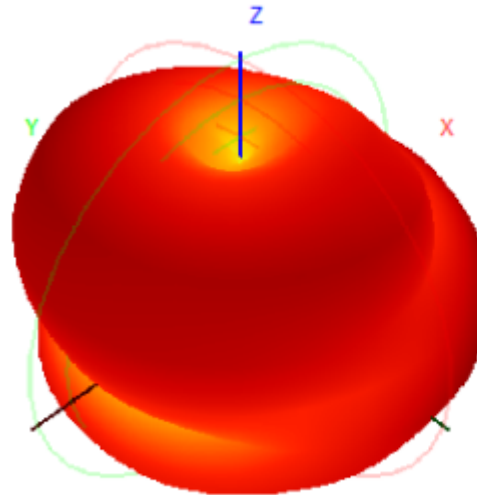

960.0MHz Total(E1-XZ), Max= 1.71dBi

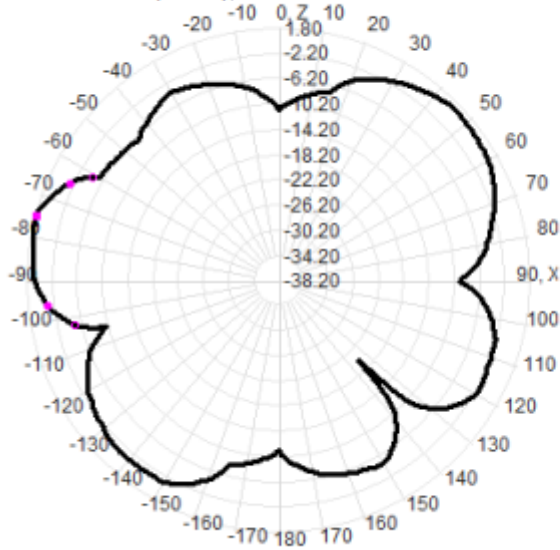

960.0MHz Total(E2-YZ), Max= 0.62dBi

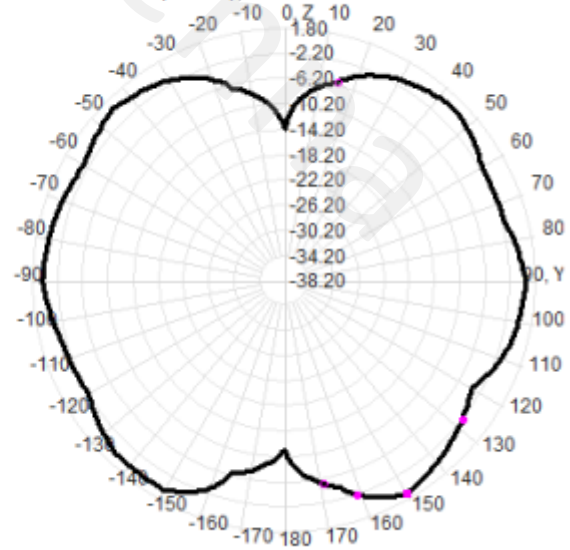

1710.0MHz H+V, Eff: 68.6%

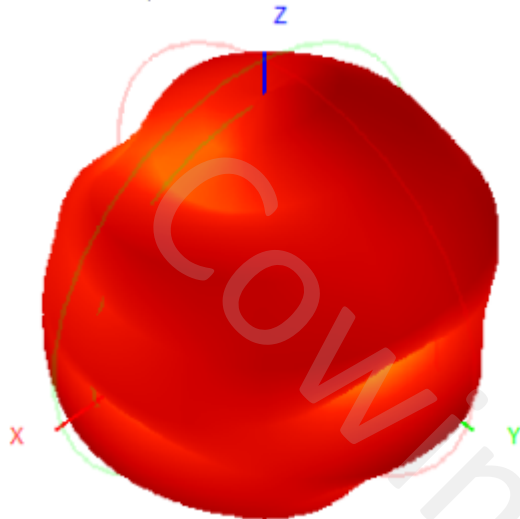

Back View

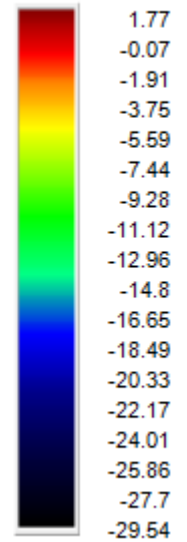
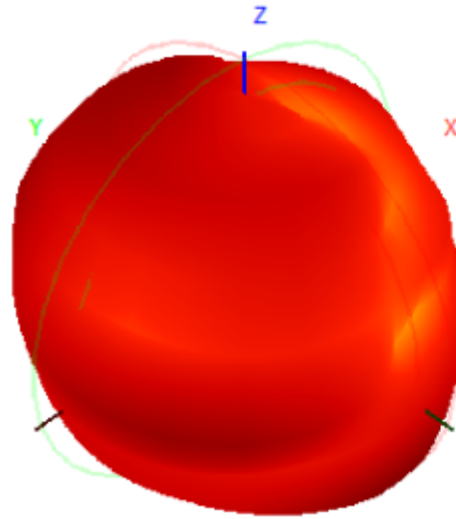

1710.0MHz Total(E1-XZ), Max= 0.90dBi

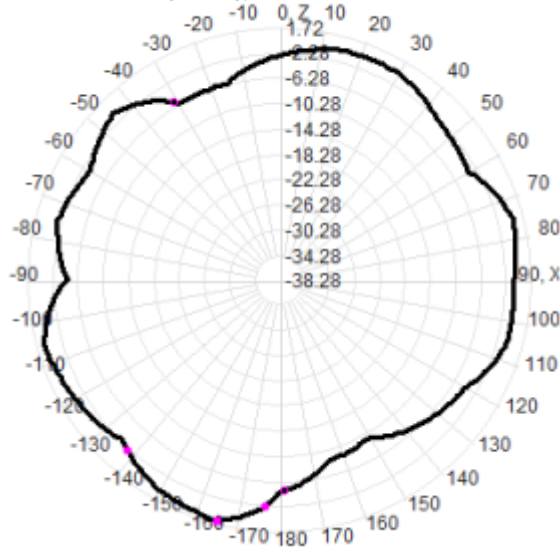

1710.0MHz Total(E2-YZ), Max= 1.72dBi

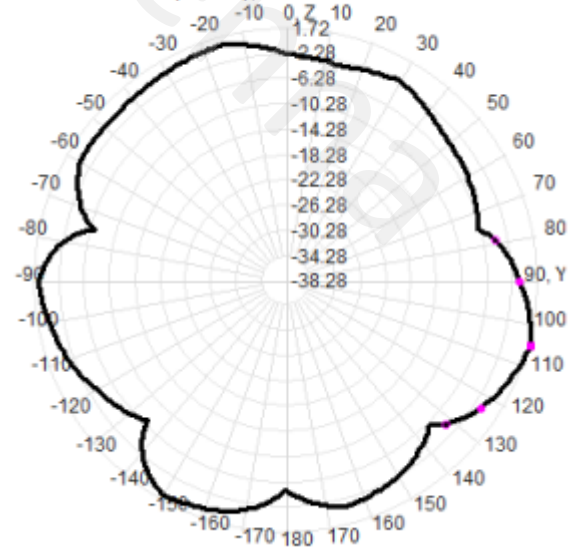

2210.0MHz H+V, Eff: 57.1%

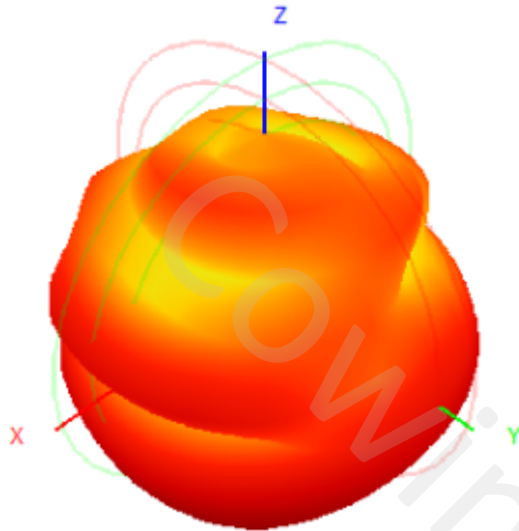

Back View

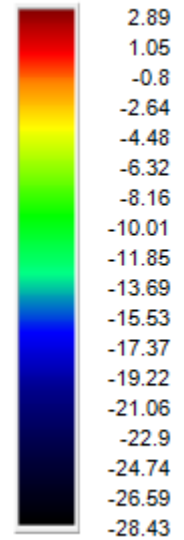
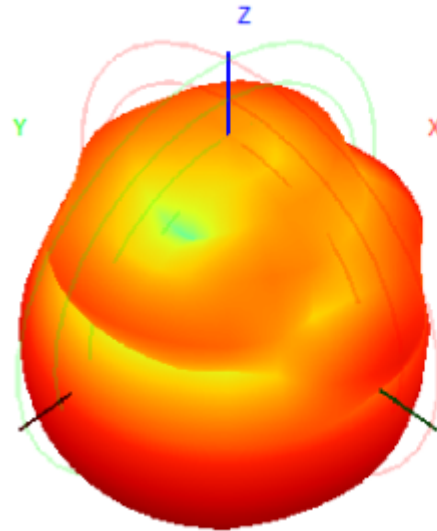

2210.0MHz Total(E1-XZ), Max= 2.66dBi

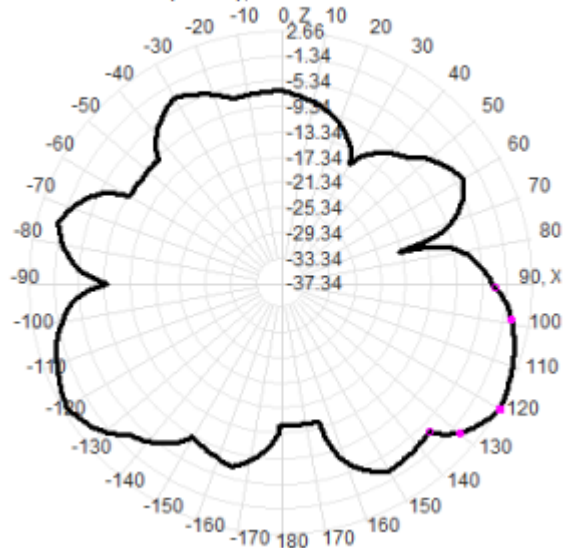

2210.0MHz Total(E2-YZ), Max= 1.15dBi

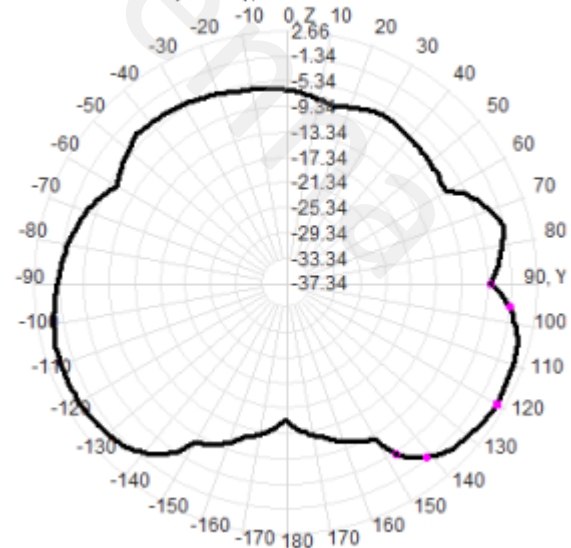

2710.0MHz H+V, Eff: 41.3%

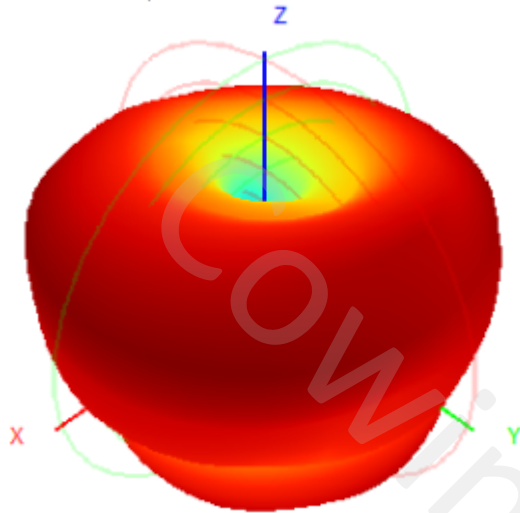

Back View

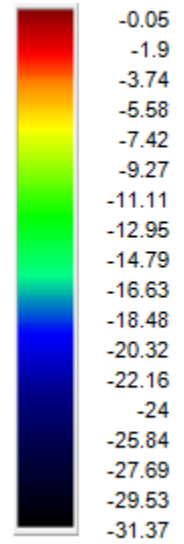
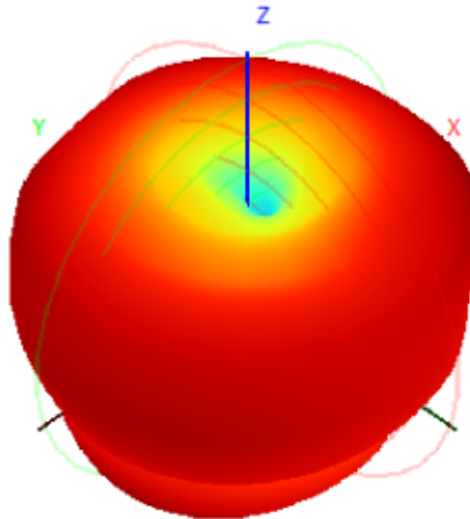

2710.0MHz Total(E1-XZ), Max=-0.28dBi

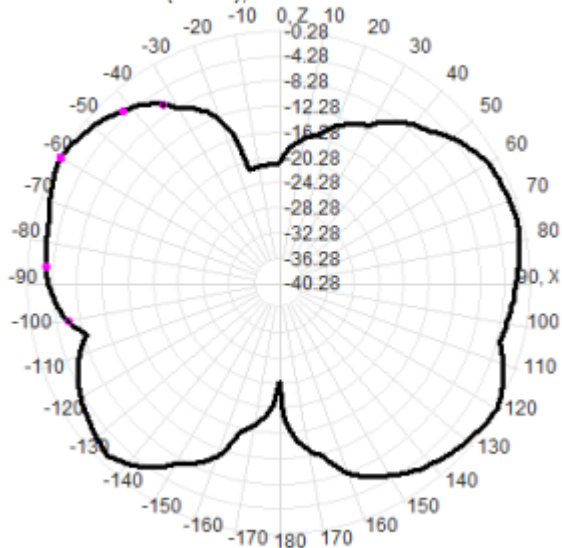

2710.0MHz Total(E2-YZ), Max=-1.64dBi

