

CW-WZ-0167

4G External Antenna

Key Features

Frequency: 824-960/1710-2700MHz

SMA Connector

Dimensions: 43.3*12mm



1. Antenna Electrical Characteristics

Band (MHz)	
Frequency (MHz)	824-960/1710-2700MHz
VSWR	≤5.0/4.0
Efficiency (%)	65.2%/78.4%
Peak Gain (dBi)	3.4/5.4
Impedance (Ohm)	50
Polarisation	Vertical
Max. Input Power (W)	10
Connector Type	SMA

2. Material and environmental characteristics

External structure	ABS+PC
Inner structure	PCB
Cable Type	RF1.37
Connector Type	SMA
Dimensions (mm)	43.3*12 MM
Antenna color	Black
Operation Temperature	-40 to +80
Storage Temperature	-40 to +80
Antenna Storage life(year)	10
Substance Compliance	ROHS

REV	Date	Description
X1	2024/02/23	New issue

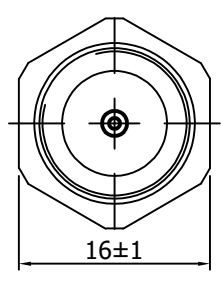
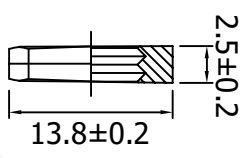
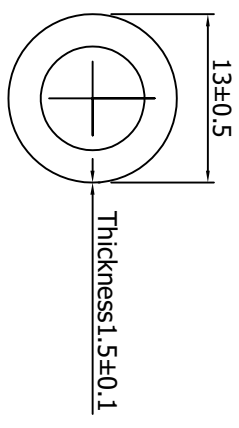
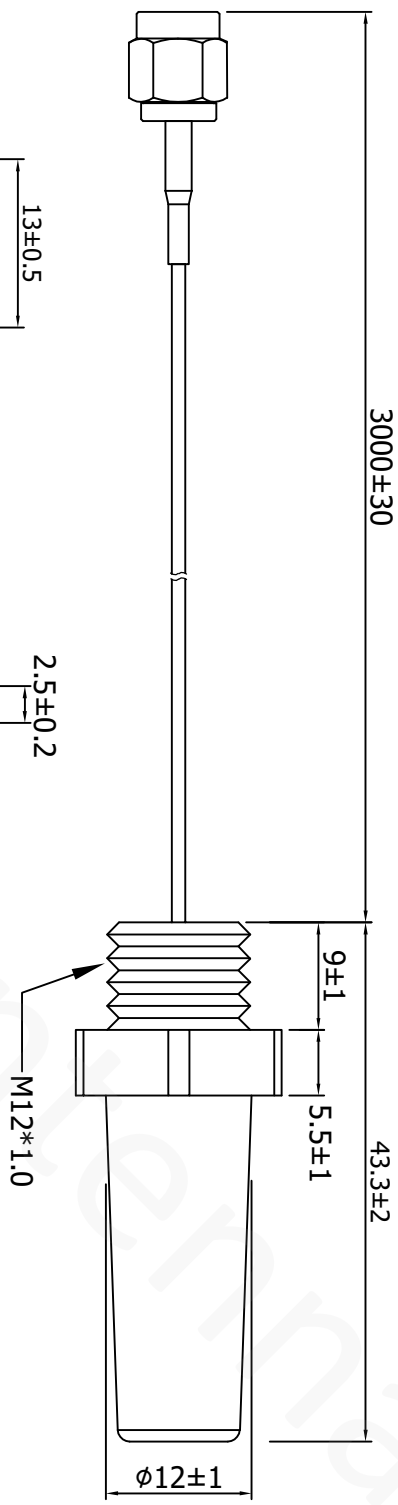

Specification(Free Test):
 Frequency Range: 824-960MHz/1710-2700MHz
 Impedance: 50Ω
 V.S.W.R: ≤5.0/4.0
 100% Continuity, short and open circuit test
 Materials, parts and process must by environmentally (ROHS)

7	Dust cap	Red silicone	1	
6	Nut	Brass plated gold	1	
5	Radome	Black ABS+PC	1	
4	Spring	Brass	1	
3	Fixing seat	Copper nickel plating	1	
2	Cable	φ1.37 Black Low loss wire	1	
1	Connector	SMA male	1	
NO	Name	Description	Q'TY	Remark
XX	±5.0	Approved		
X	±3.0	Checked		
X	±1.0			
.XX	±0.2	Drawing		
.XXX	±0.1			
		Customer		
		Part NO.		
		Part name	External antenna	
		CW P/NO.	CW-WZ-0167	
REV	Unit	File		
X1	m/m	Sheet:	1/1	



4. Antenna test parameters

Antenna Measurement Conditions:

Mounted on Ground Plane of 280 x 80 mm

Measured in Certified 3D Anechoic Chamber

The network analyzer is Agilent 5071c

The comprehensive tester is Agilent cmv500

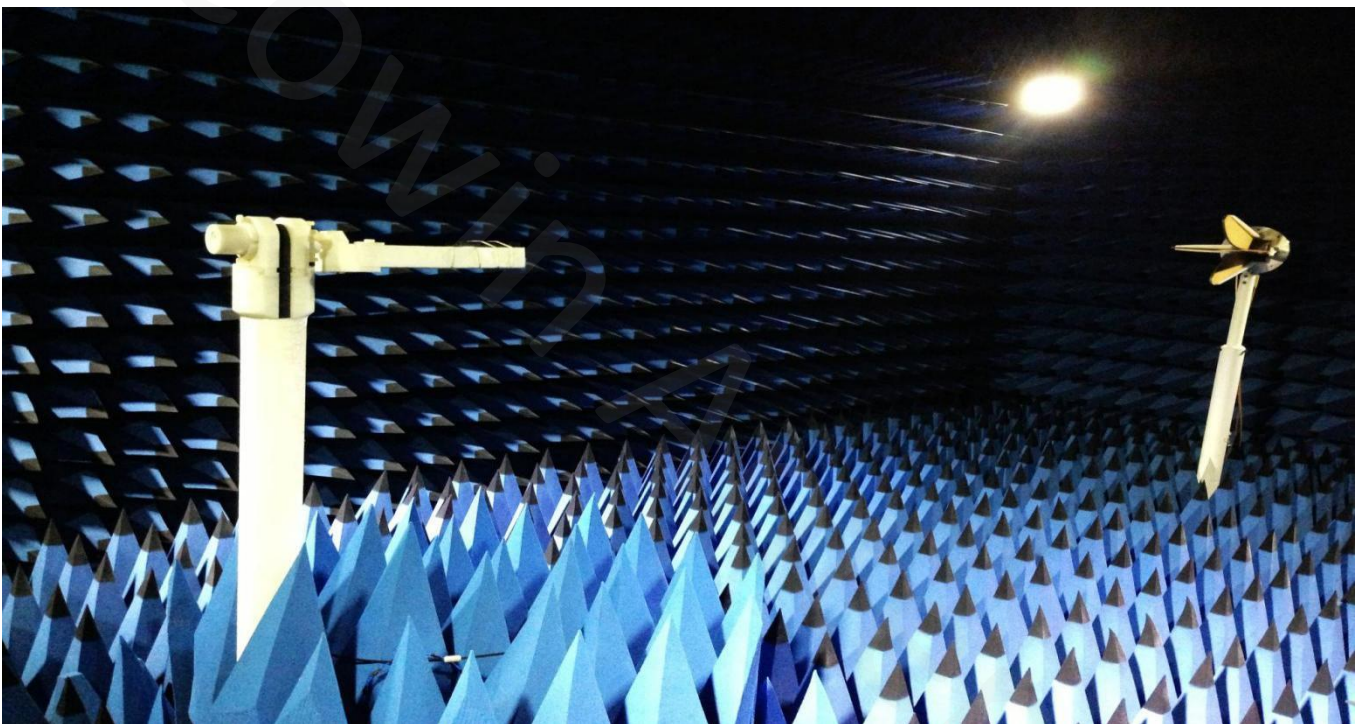

4.1 VSWR

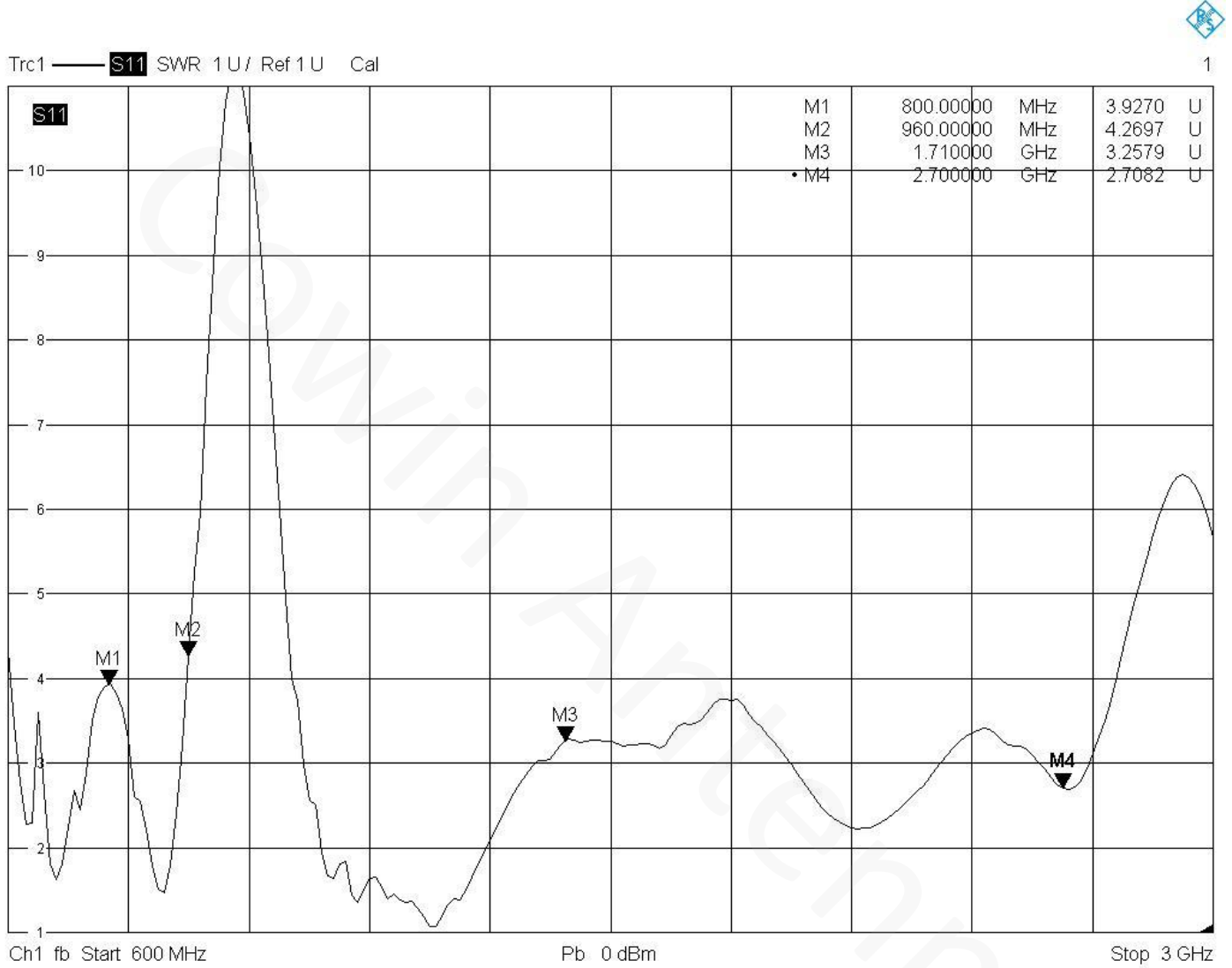

4.2 Efficiency

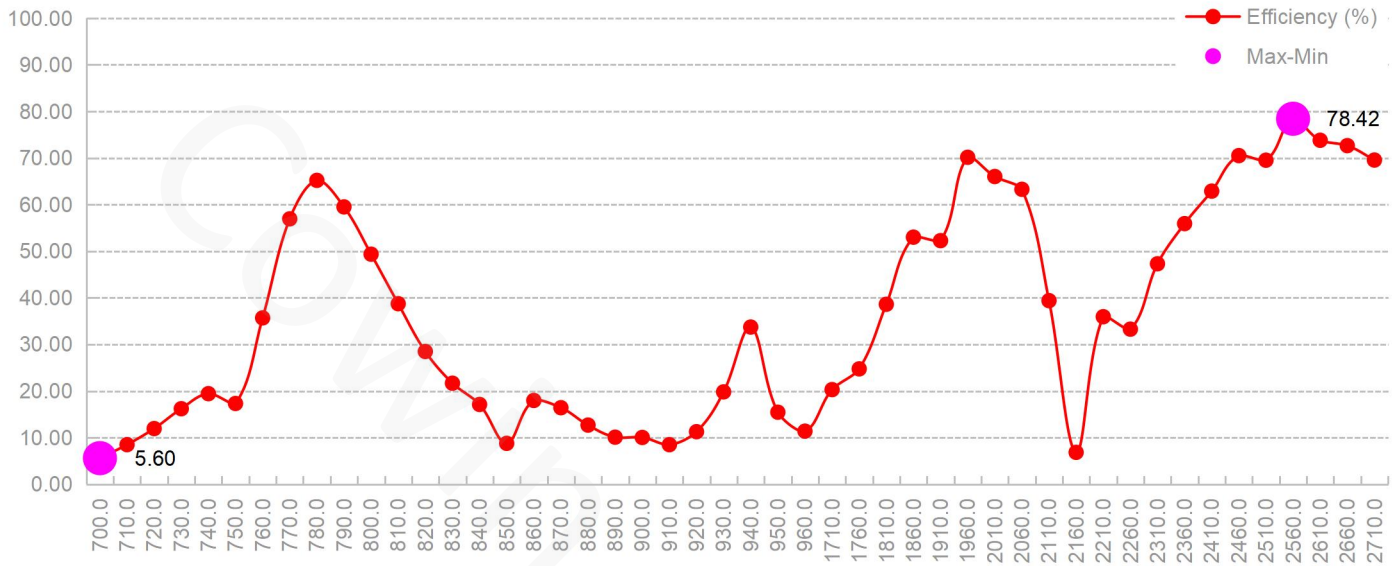

4.3 Peak gain

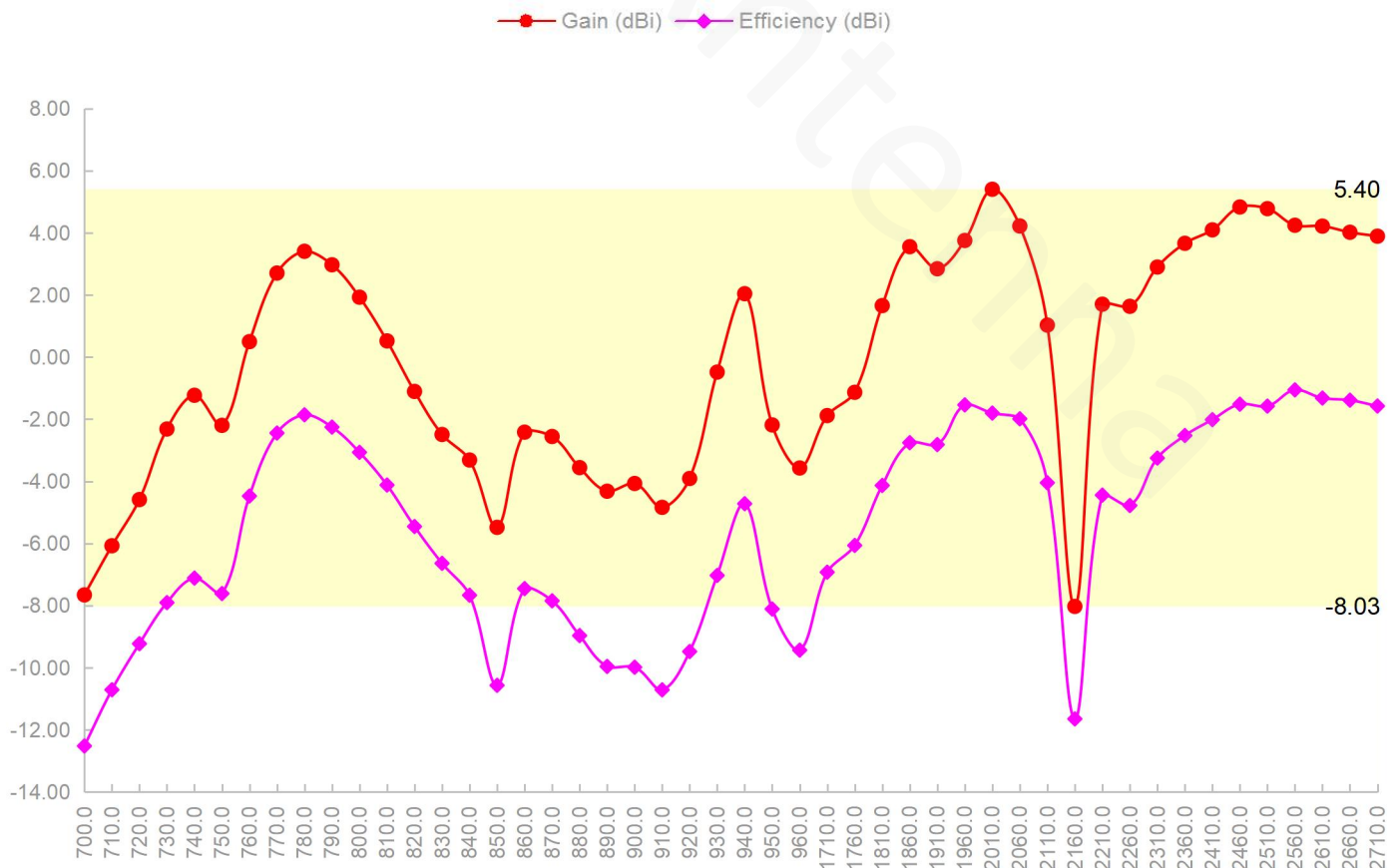

4.4 3D&2D Radiation Patterns

700.0MHz H+V, Eff: 5.6%

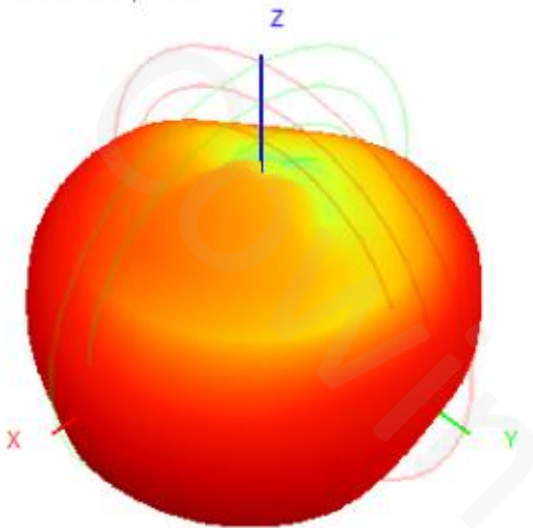

Back View

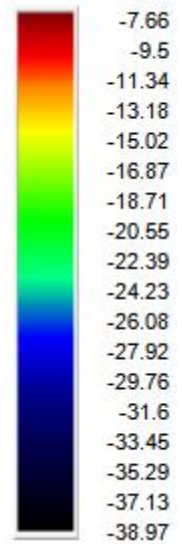
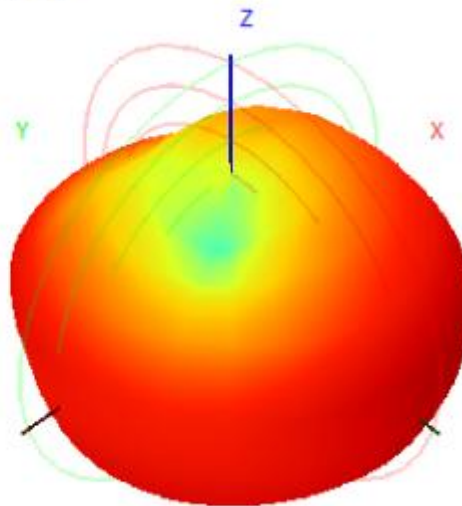

700.0MHz Total(E1-XZ), Max=-8.02dBi

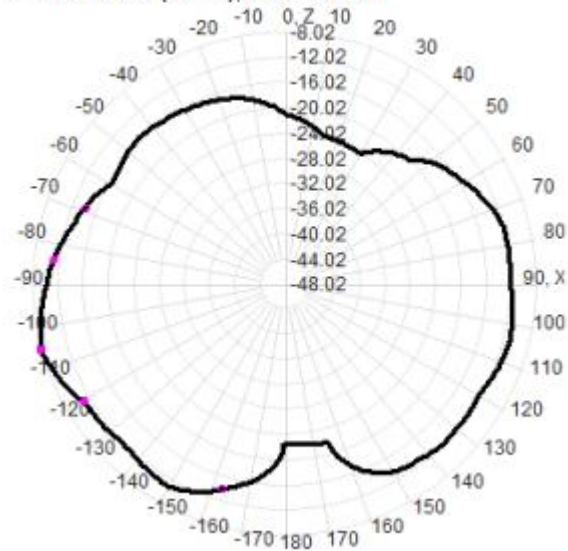

700.0MHz Total(E2-YZ), Max=-9.46dBi

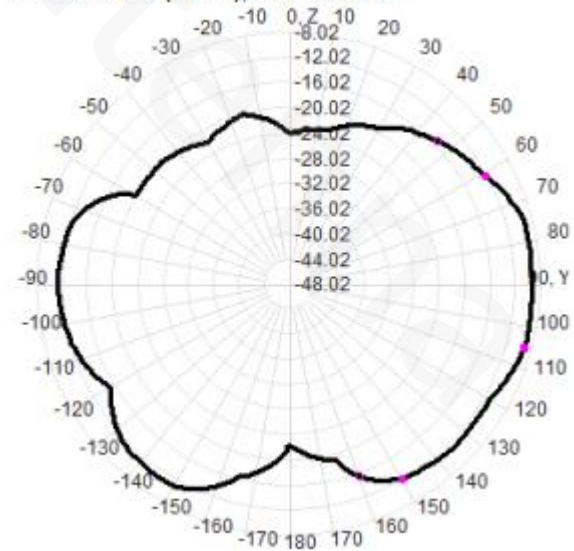

780.0MHz H+V, Eff: 65.2%

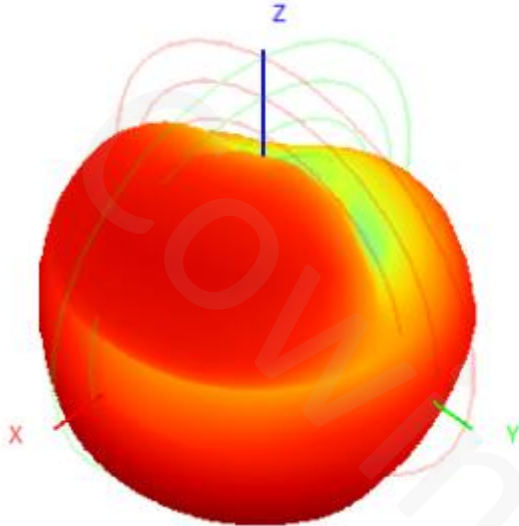

Back View

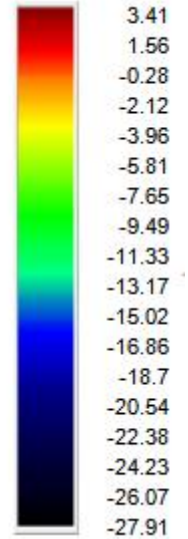
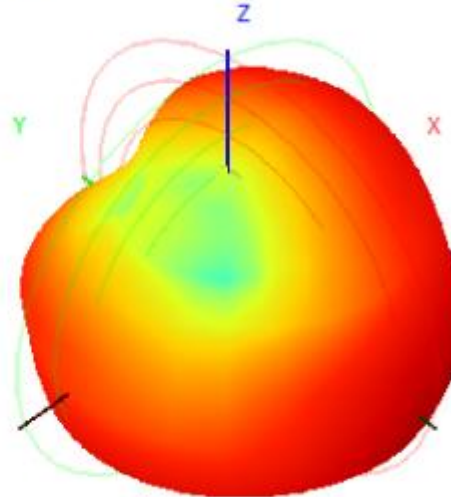

780.0MHz Total(E1-XZ), Max= 2.49dBi

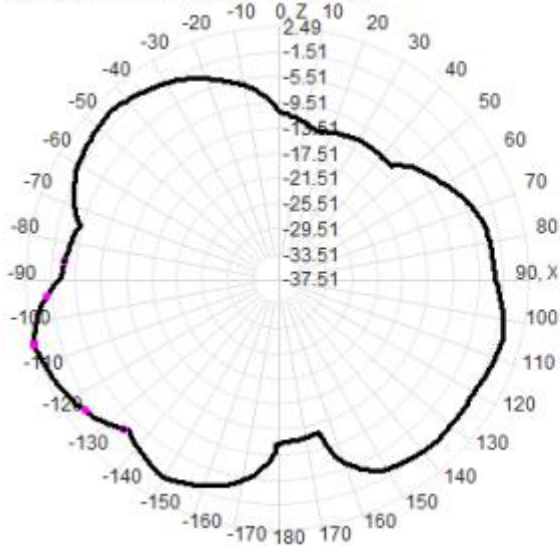

780.0MHz Total(E2-YZ), Max= 2.19dBi

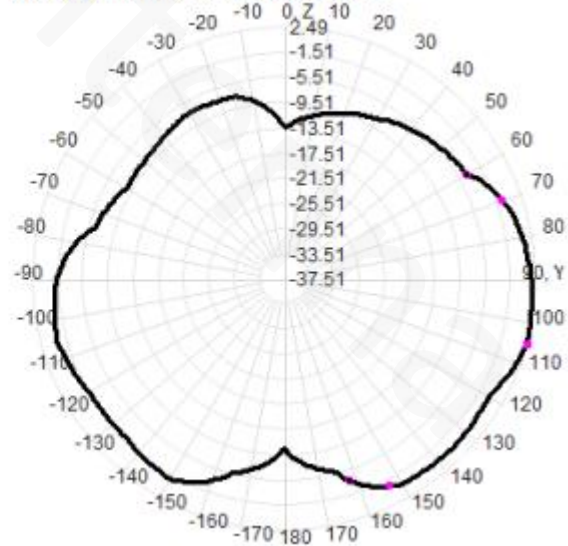

820.0MHz H+V, Eff: 28.5%

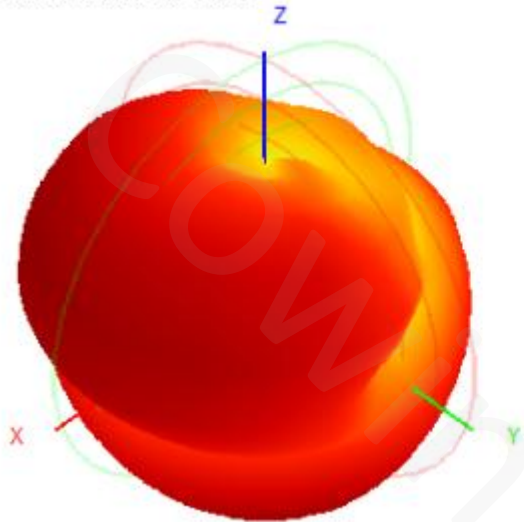

Back View

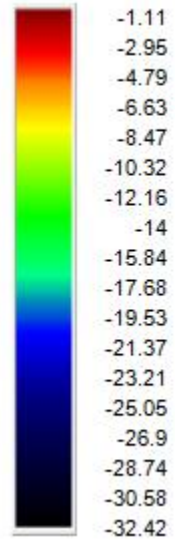
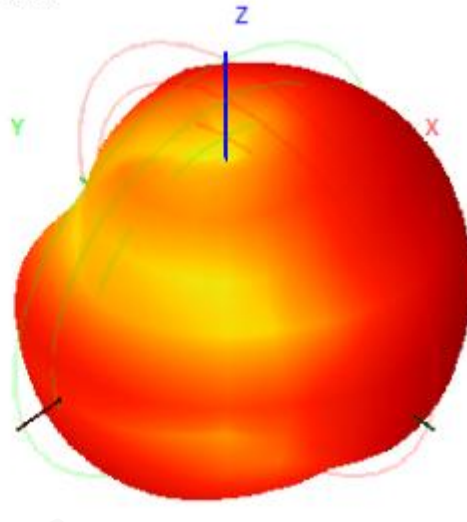

820.0MHz Total(E1-XZ), Max= -1.97dBi

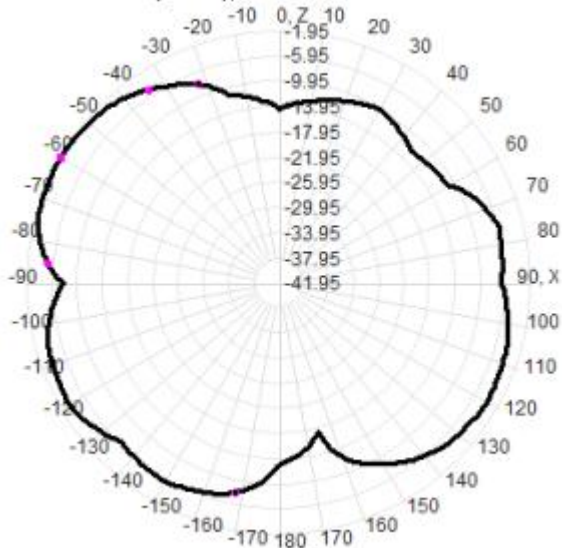

820.0MHz Total(E2-YZ), Max= -3.21dBi

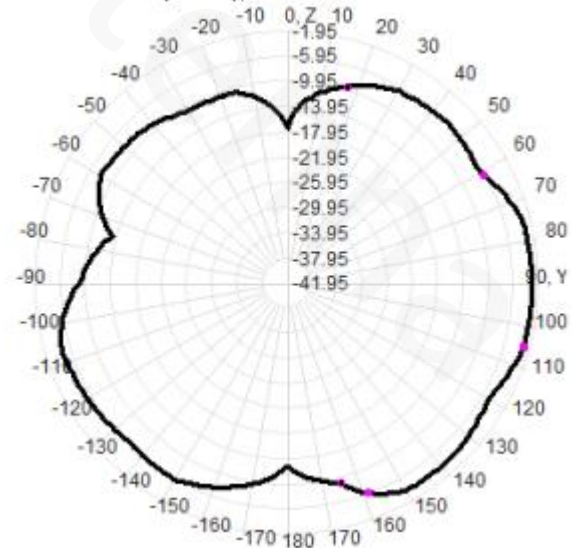

960.0MHz H+V, Eff: 11.4%

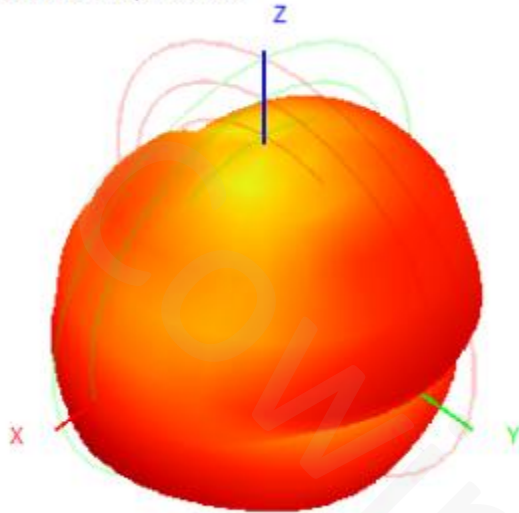

Back View

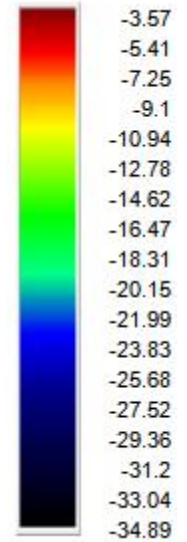
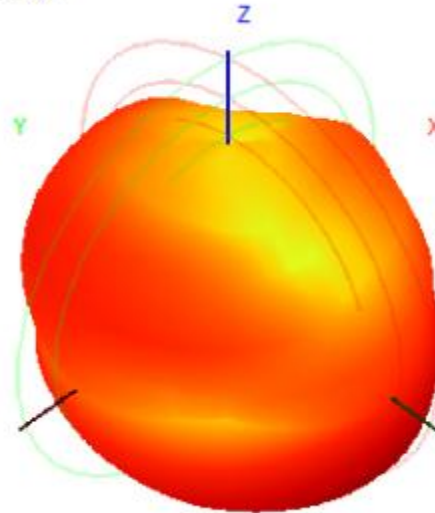

960.0MHz Total(E1-XZ), Max= -4.74dBi

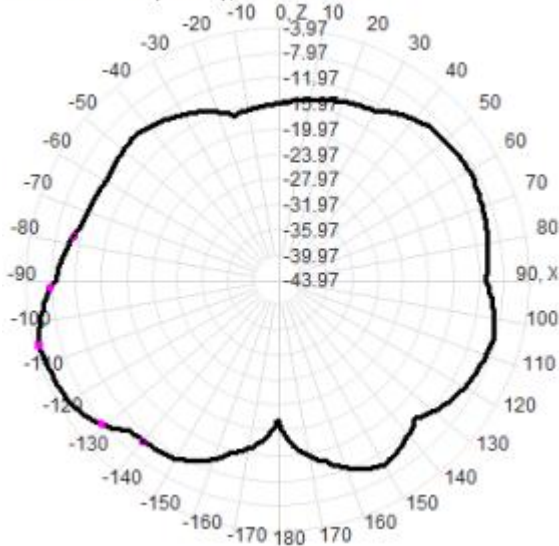

960.0MHz Total(E2-YZ), Max= -3.97dBi

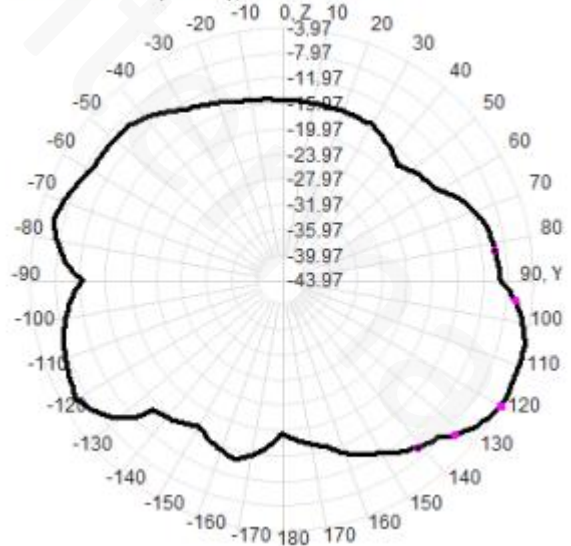

1710.0MHz H+V, Eff: 20.3%

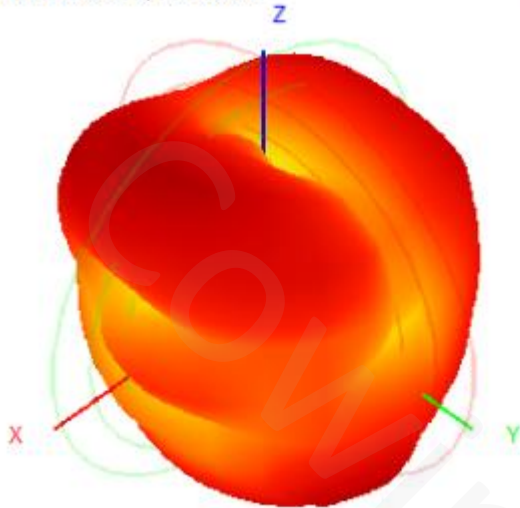

Back View

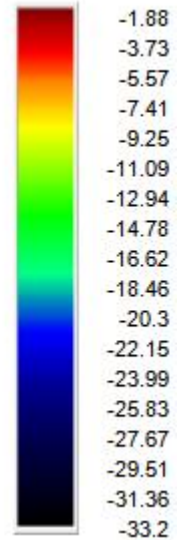
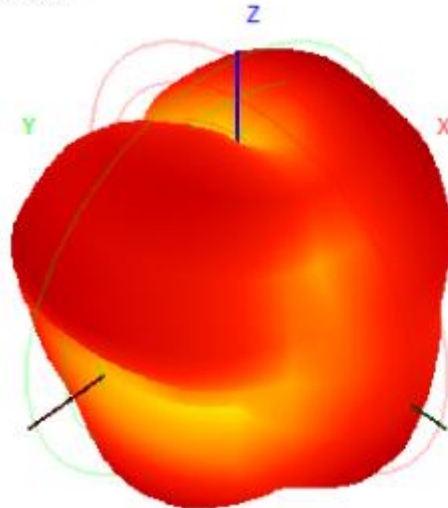

1710.0MHz Total(E1-XZ), Max= -3.45dBi

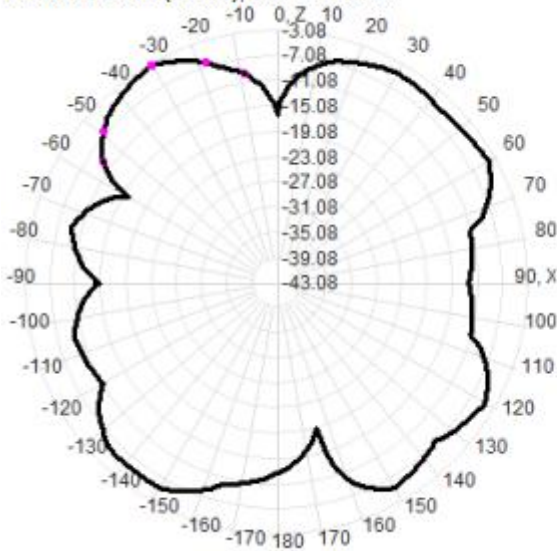

1710.0MHz Total(E2-YZ), Max= -3.08dBi

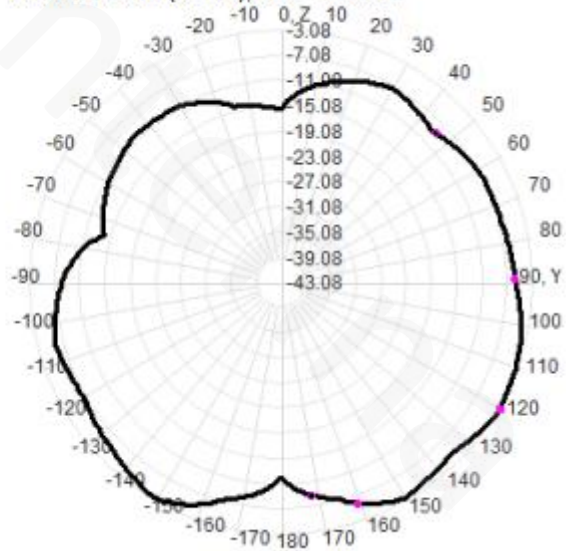

2310.0MHz H+V, Eff: 47.3%

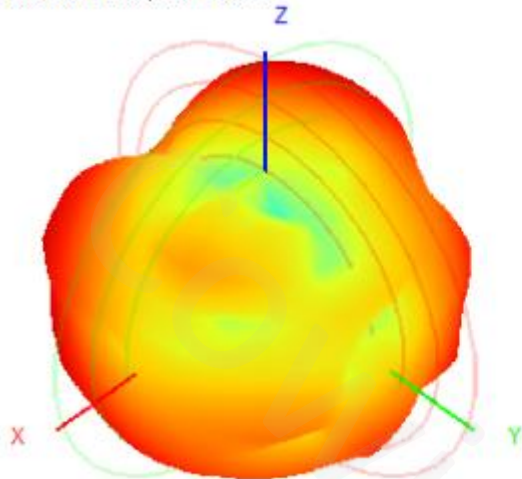

Back View

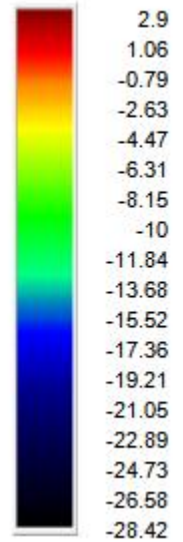
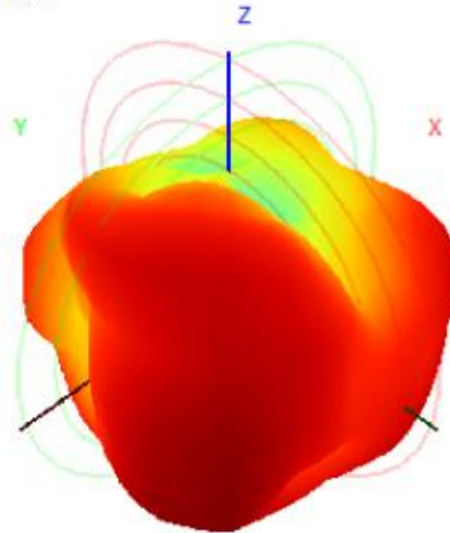

2310.0MHz Total(E1-XZ), Max= 0.53dBi

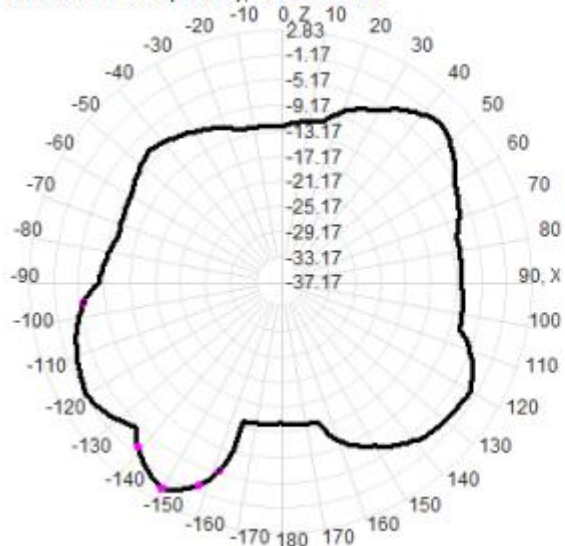

2310.0MHz Total(E2-YZ), Max= 0.64dBi

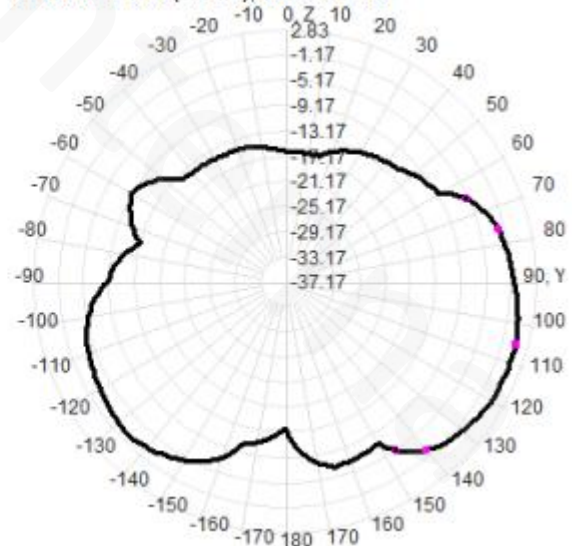

2710.0MHz H+V, Eff: 69.6%

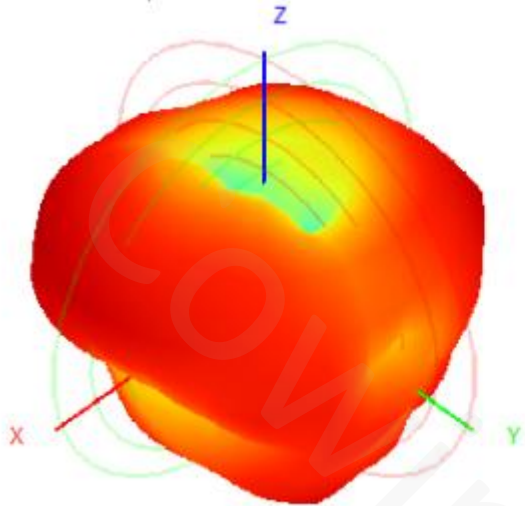

Back View

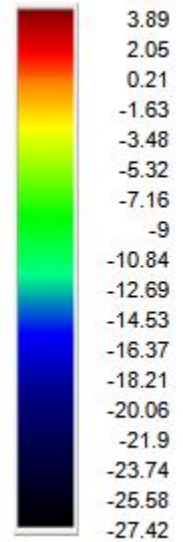
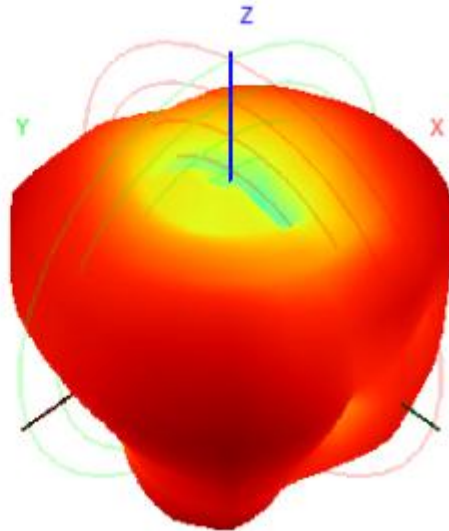

2710.0MHz Total(E1-XZ), Max= 1.32dBi

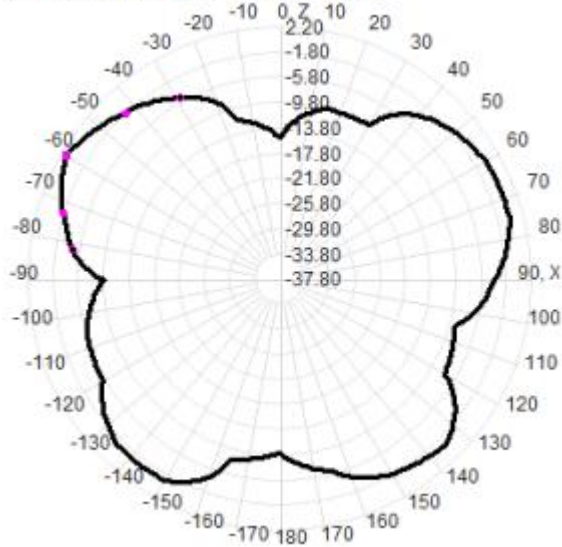

2710.0MHz Total(E2-YZ), Max= 0.68dBi

