

CW-ZH-0005

4G/2.4G/GPS External Combo Antenna

Key Features

Frequency: 698-960MHz/1710-2700MHz/2.4-2.5G/1560-1610MHz

SMA Male Connector

Screw Mount

Dimensions 80*15mm



1. Antenna Electrical Characteristics

Band (MHz)			
Frequency (MHz)	698-960MHz	1710-2700MHz	2.4-2.5G
VSWR	2.5:1	2:1	2:1
Efficiency (%)	80.58%	77.21%	61.69%
Peak Gain (dBi)	2.89	4.09	3.33
Impedance (Ohm)	50		
Polarisation	Vertical		
Max. Input Power (W)	10		
Connector Type	SMA Male		

Band (MHz)			
Frequency (MHz)	1560MHz	1575MHz	1605MHz
VSWR	2:1	2:1	2:1
Efficiency (%)	21.03%	42.69%	63.62%
Peak Gain (dBi)	-0.73	2.35	4.31
LNA Specification			
Gain(dbi)	26.86	26.22	25.46
Impedance (Ohm)	50		
Polarisation	RHCP		
Max. Input Power (W)	3-5		
Connector Type	SMA male		

2. Material and environmental characteristics

Inner structure	PCB/Ceramic antenna
External material	ABS
Cable Type	RG174
Connector Type	SMA Male
Dimensions (mm)	80*15MM
Antenna color	Black
Operation Temperature	-40 to +80
Storage Temperature	-40 to +80
Antenna Storage life(year)	10
Substance Compliance	ROHS

REV	Date	Description
X1	2022/08/02	New issue

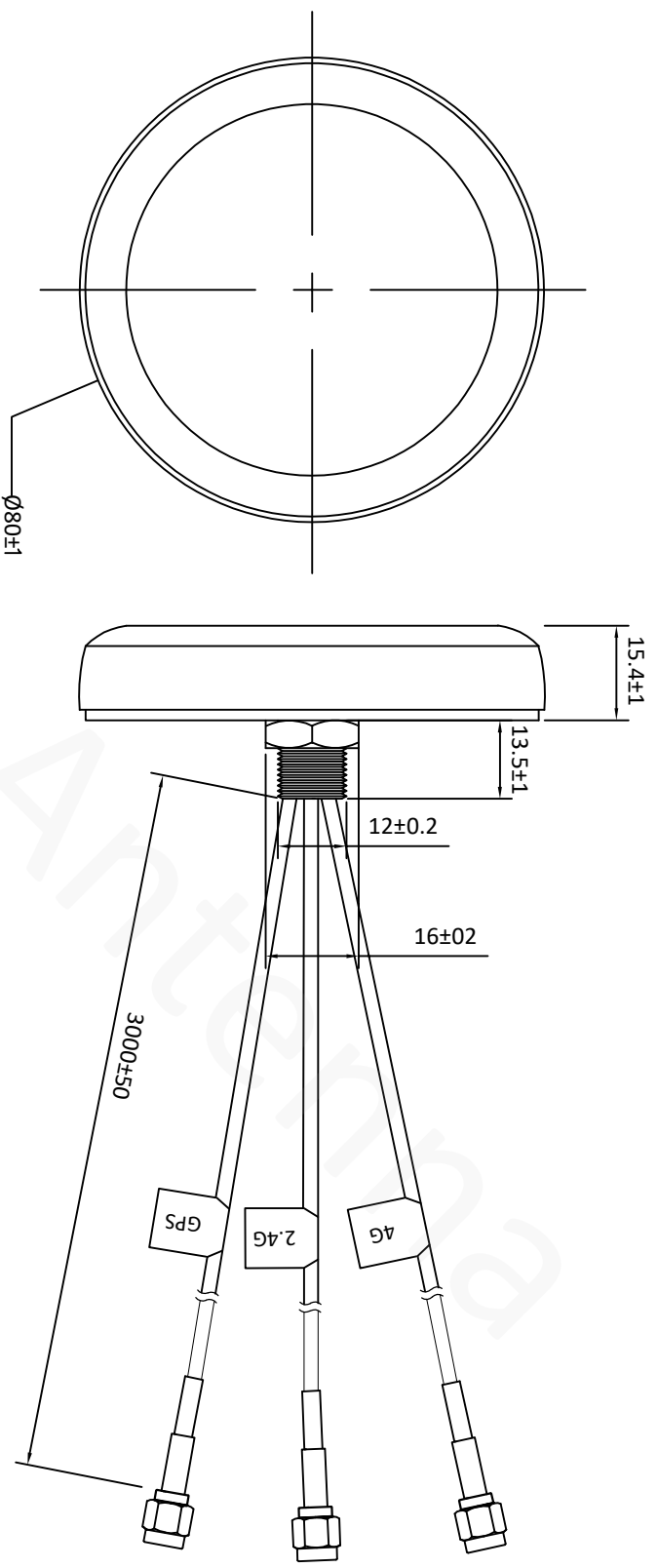

Specification(Free Test):

Frequency Range: 698-960MHZ/1710-2700MHZ
 Impedance: 50Ω
 V.S.W.R: ≤2.5/2

Specification(Free Test):

Frequency Range: 2.4-2.5G
 Impedance: 50Ω
 V.S.W.R: ≤2

Specification(Free Test):

Frequency Range: 1575.42MHZ
 Impedance: 50Ω
 V.S.W.R: ≤2

9	Ceramic antenna	25*25*4MM	1	
8	Label	36*10MM	3	
7	Foam rubber	79*1MM	1	
6	Stud	Nickel plated brass	1	
5	Lower cover	Black ABS	1	
4	Shell	Black ABS	1	
3	Cable	RG174	1	
2	PCB	FR4	2	
1	Connector	SMA male	3	
NO	Name	Description	QTY	Remark
XX.	±5.0	Approved		
X.	±3.0			
.X	±1.0	Checked		
.XX	±0.2			
.XXX	±0.1	Drawing		
		Customer		
		Part NO.		
		Part name	Combined antenna	
		CW P/NO.	CW-ZH-0005	
		REV	X1	
		Unit	m/m	
		File		
		Sheet	1/1	



4. Antenna test parameters

Antenna Measurement Conditions:

Mounted on Ground Plane of 280 x 80 mm

Measured in Certified 3D Anechoic Chamber

The network analyzer is Agilent 5071c

The comprehensive tester is Agilent cmv500

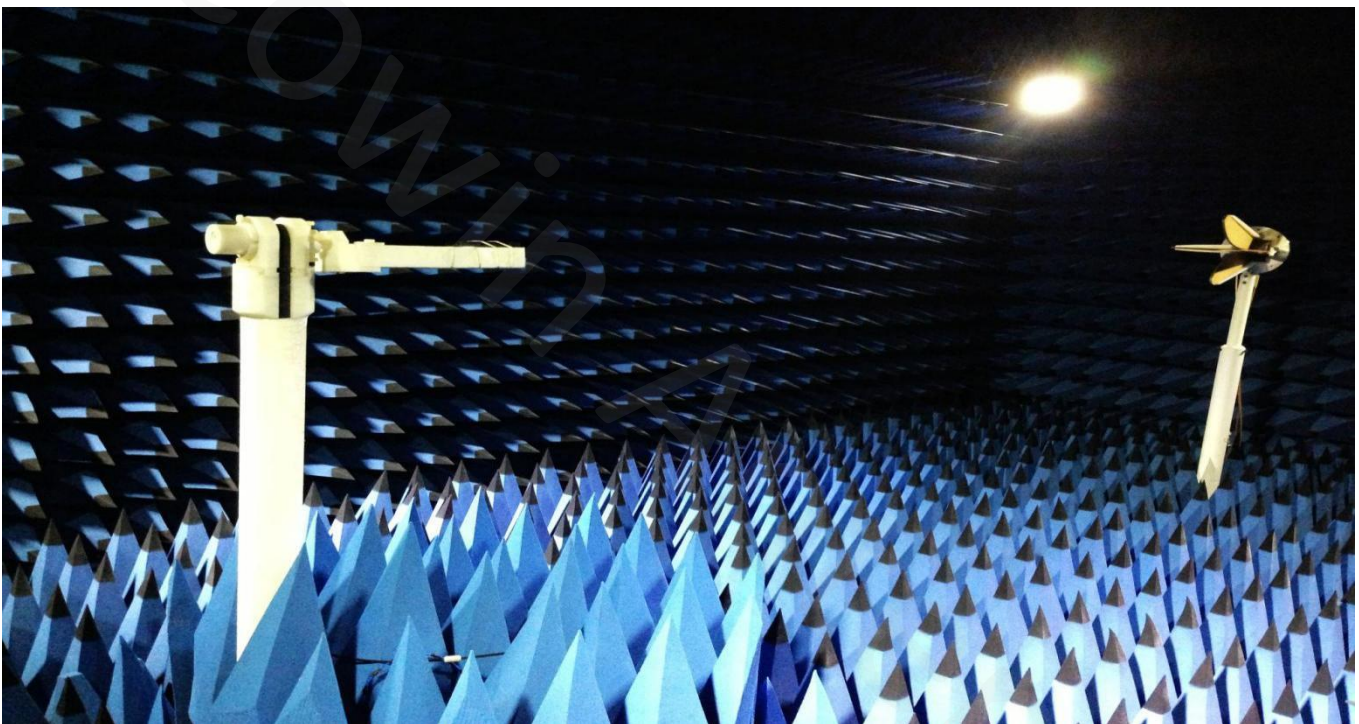

4.1 VSWR

4.1.1 4G VSWR

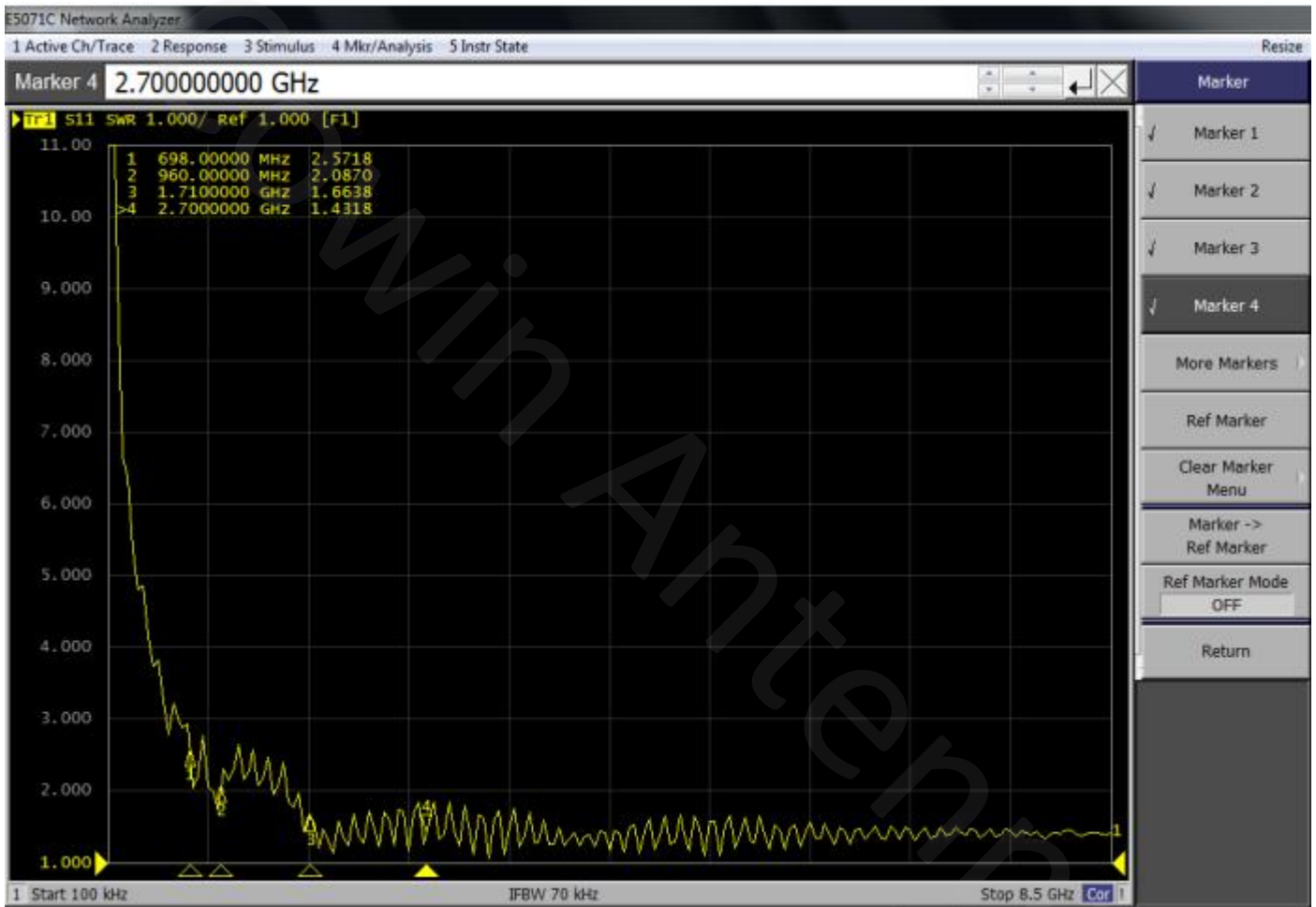

4.1.2 WIFI VSWR

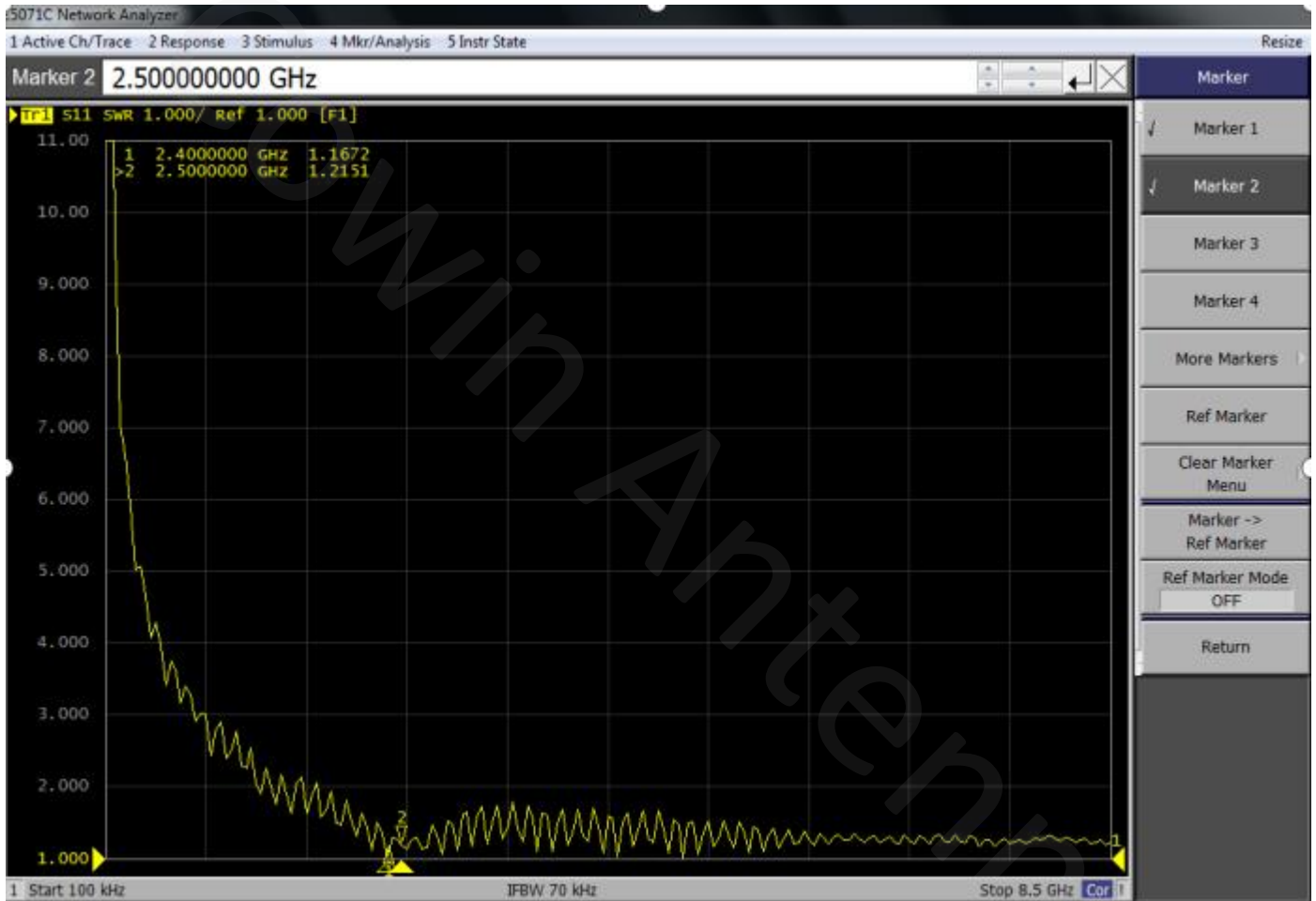

4.1.3 GPS VSWR

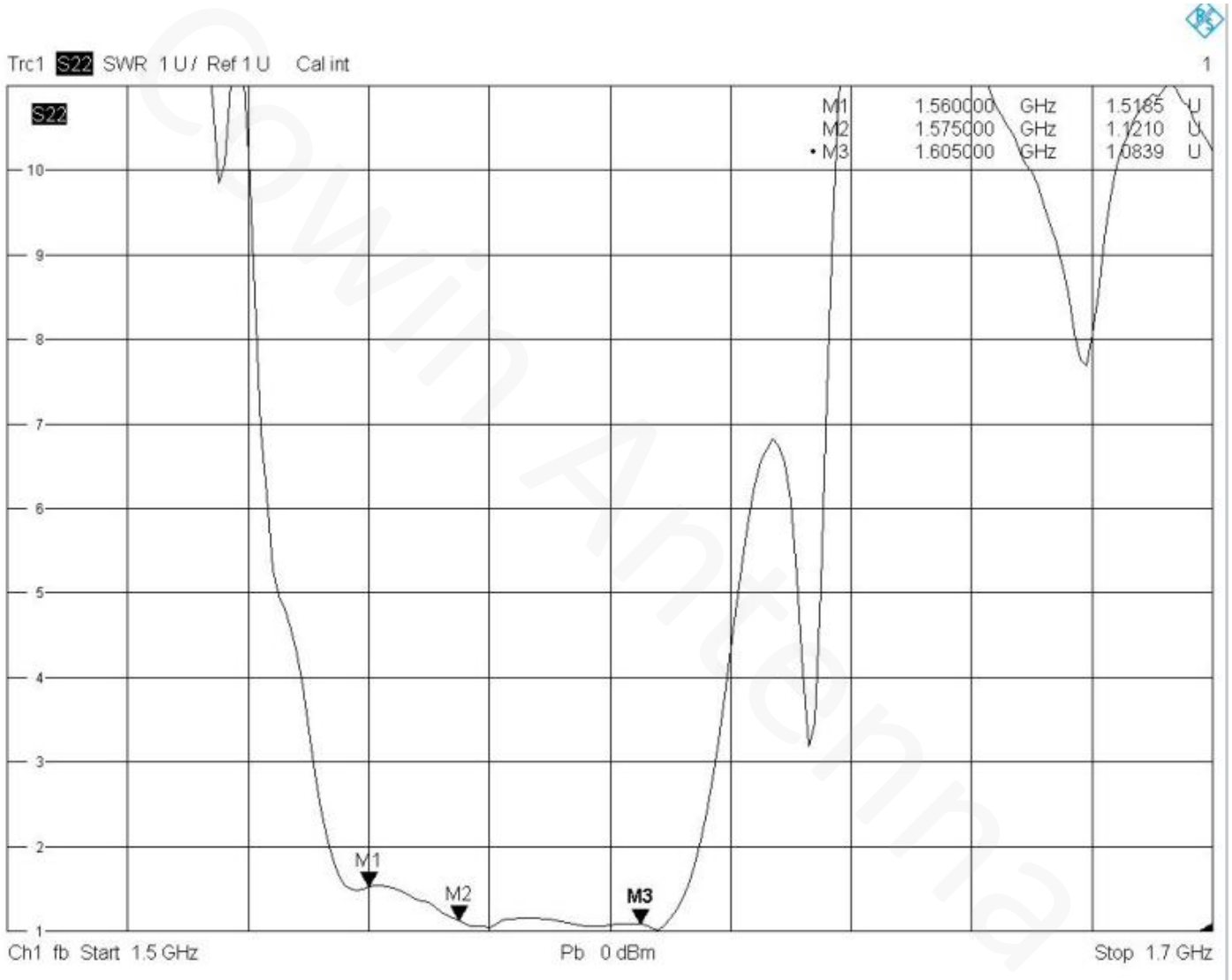

4.2 Efficiency&Peak gain

4.2.1 4G Efficiency

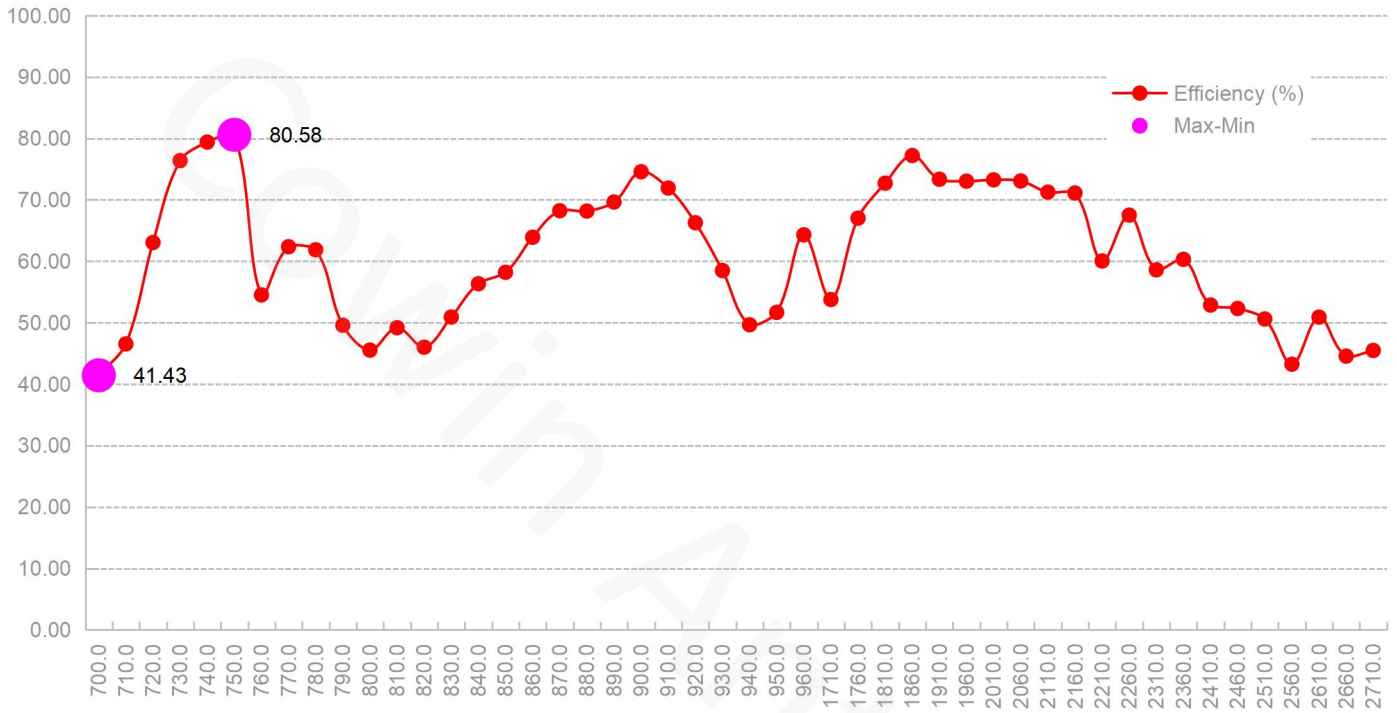

4.2.2 4G Peak gain

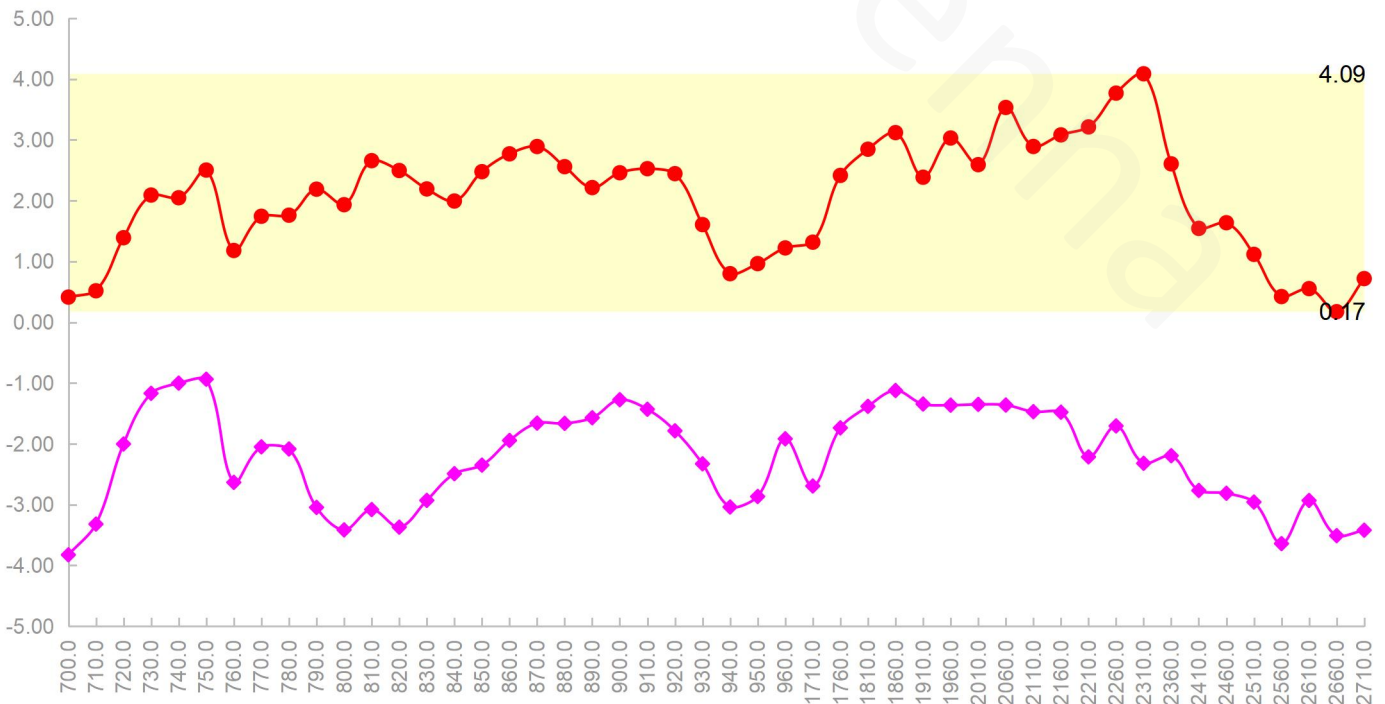

4.2.3 WIFI Efficiency

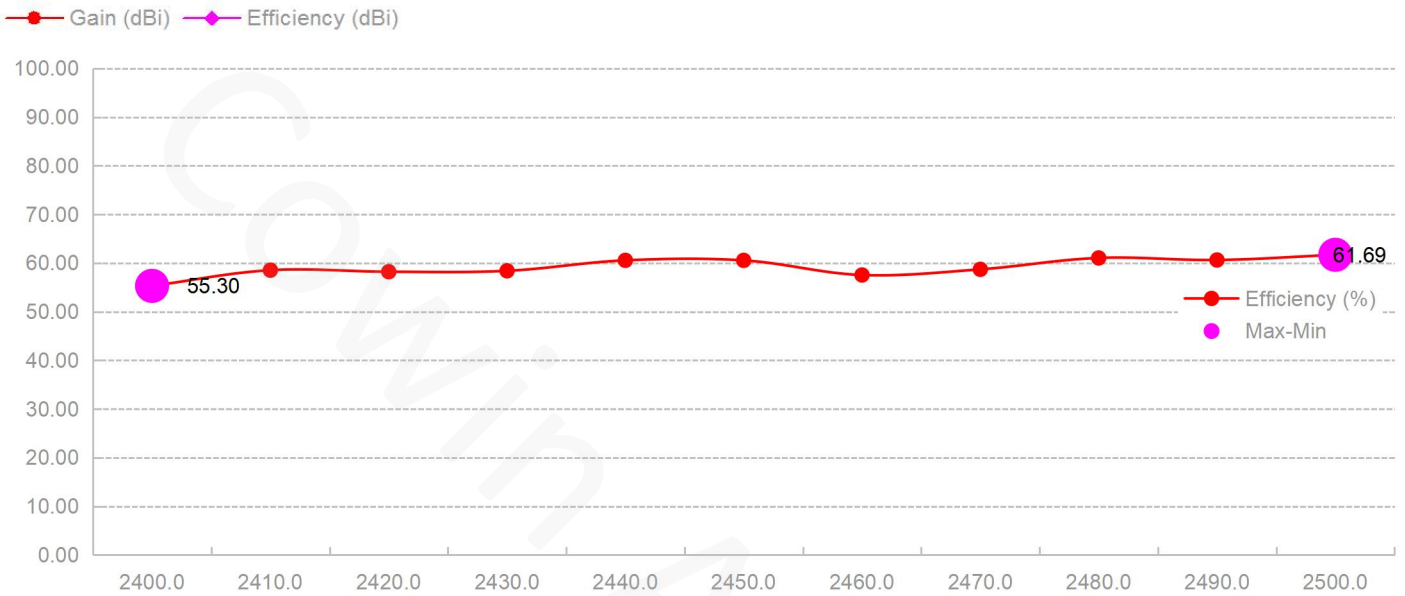

4.2.4 WIFI Peak gain

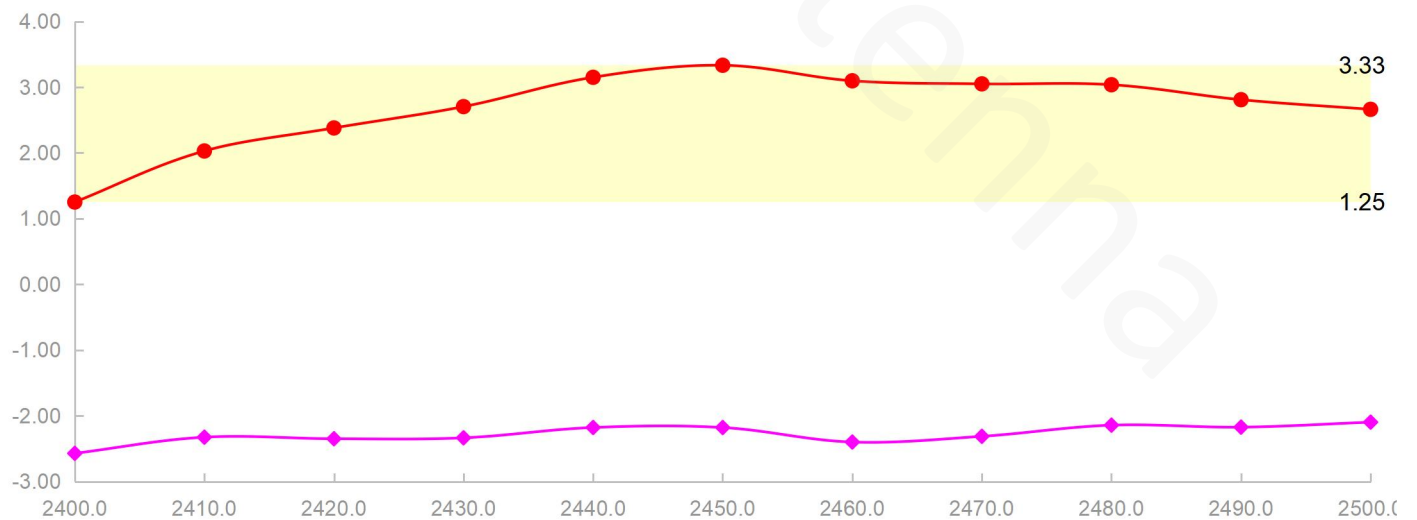

4.2.5 GPS Passive antenna efficiency

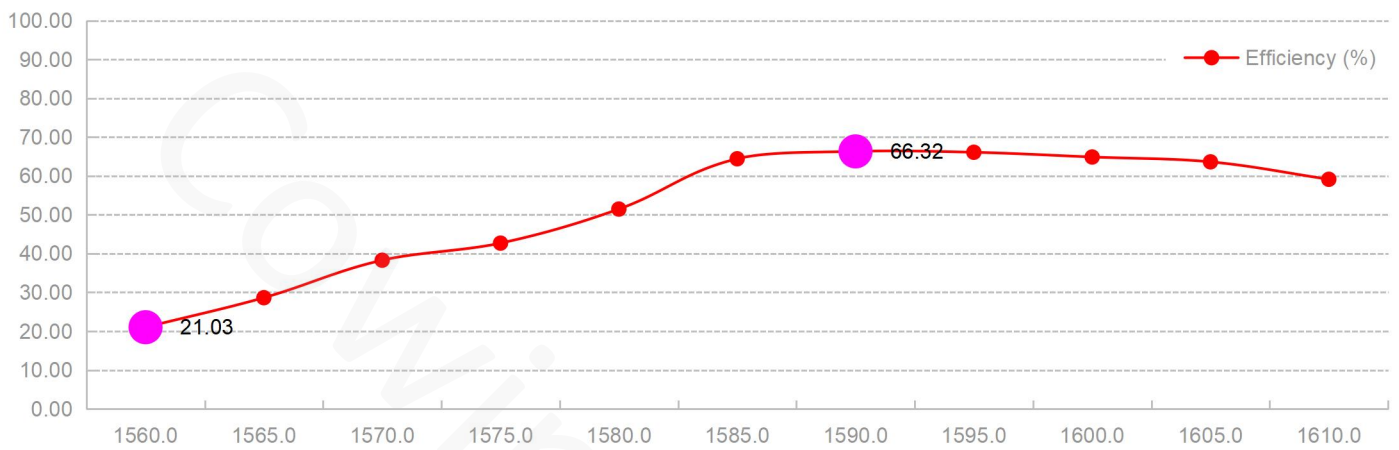

4.2.6 GPS Passive antenna peak gain

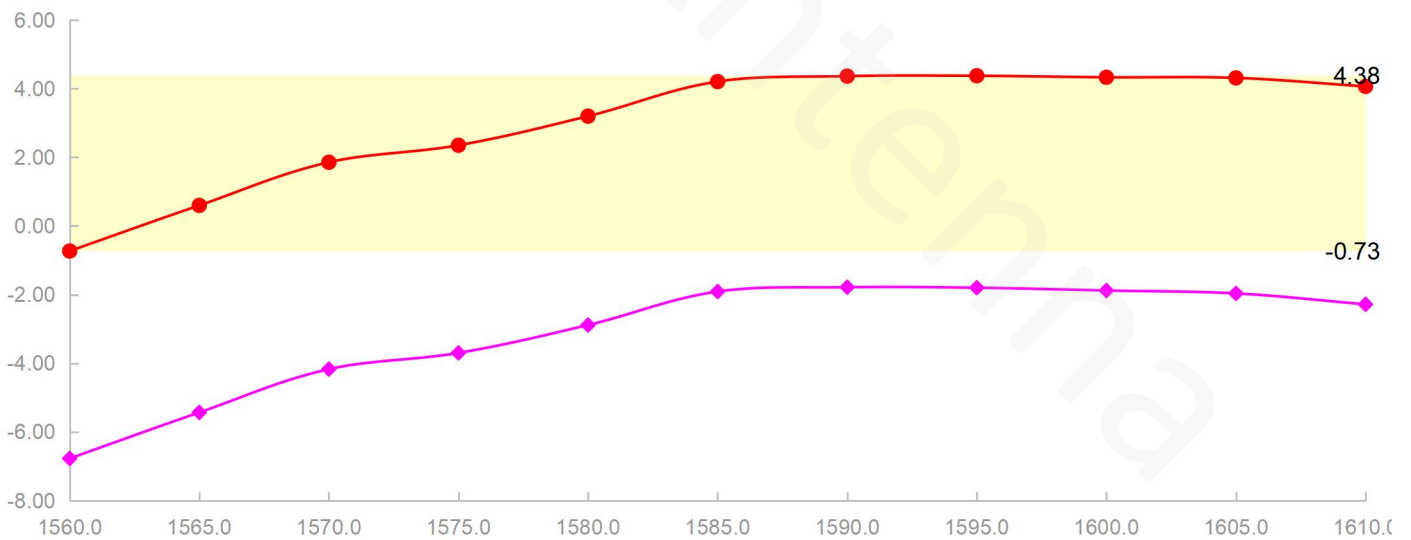

4.2.7 GPS Active antenna peak gain

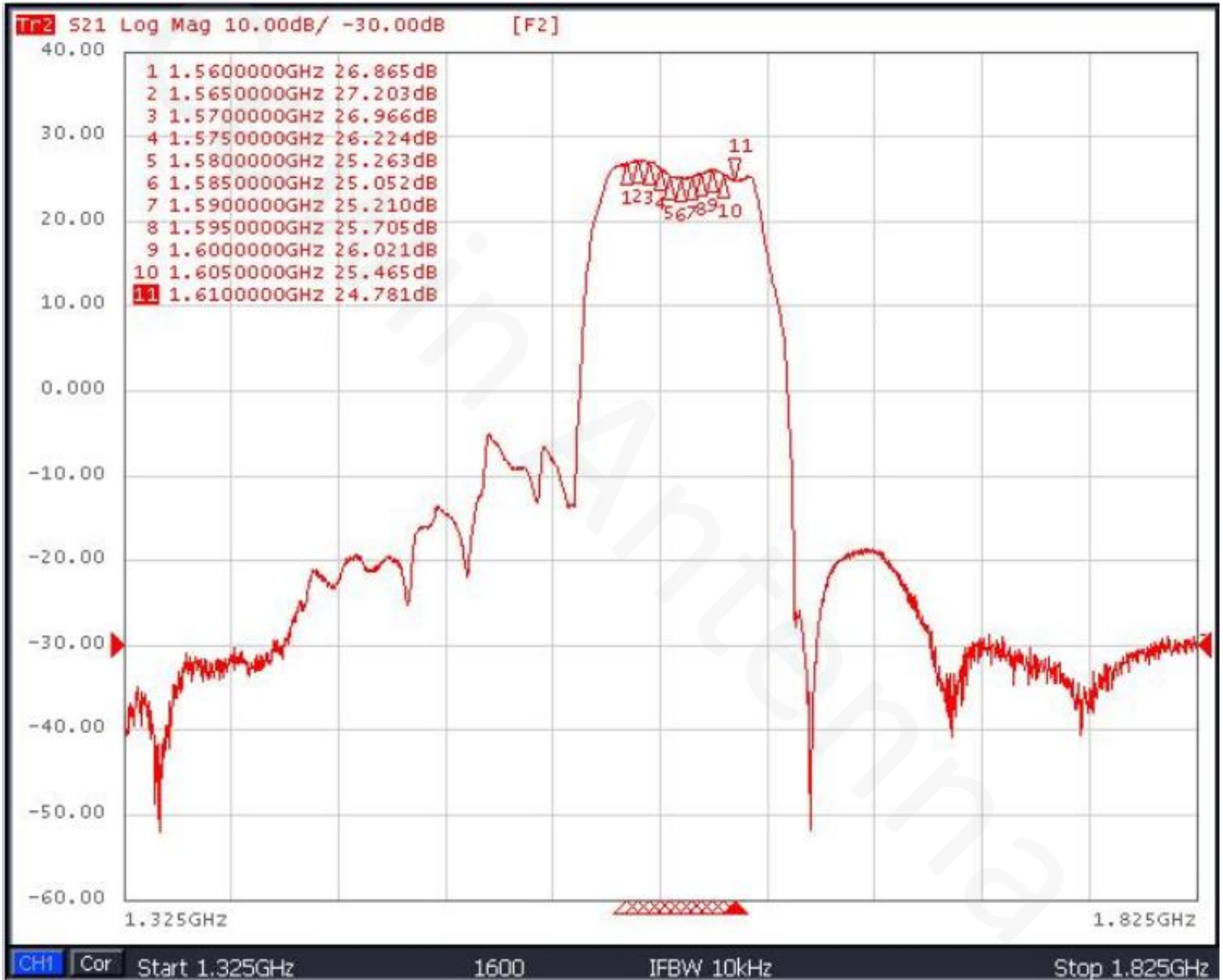

4.3 4G 3D&2D Radiation Patterns

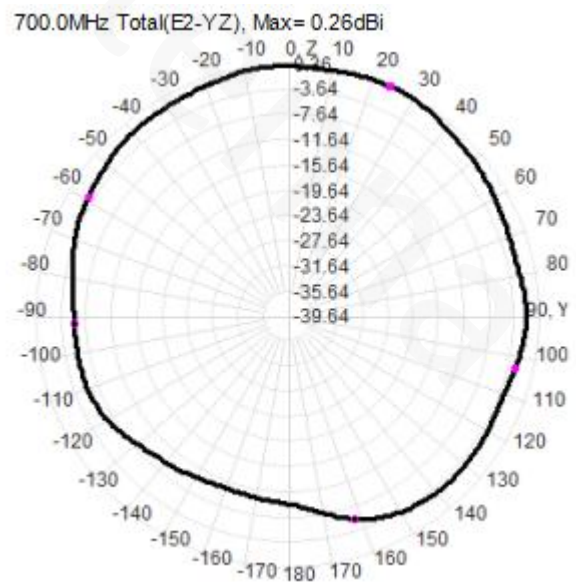
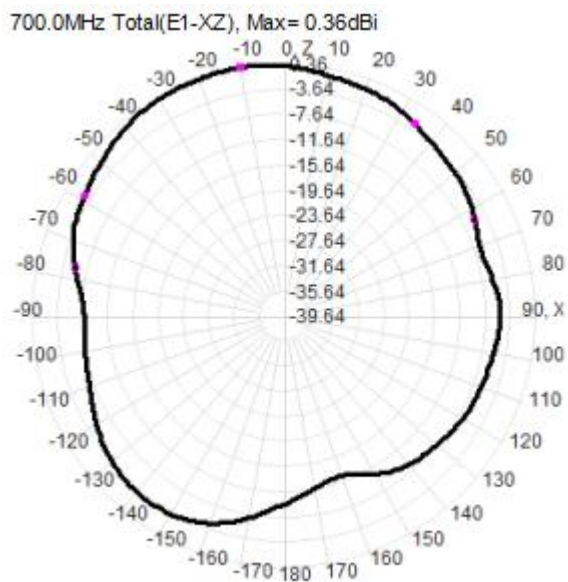
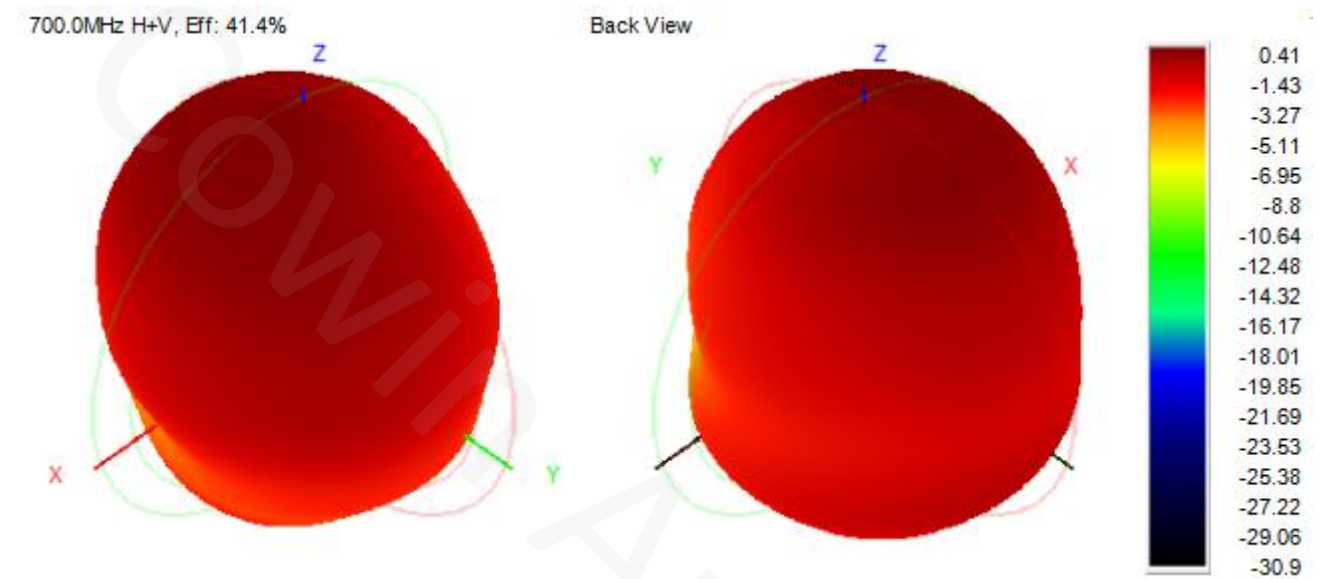

860.0MHz H+V, Eff: 63.9%

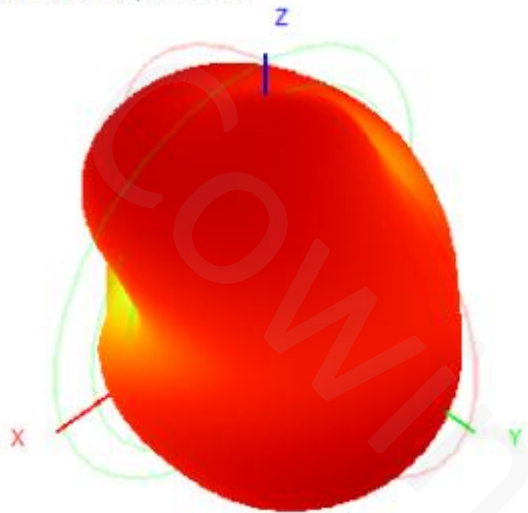

Back View

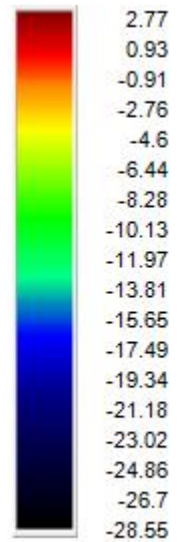
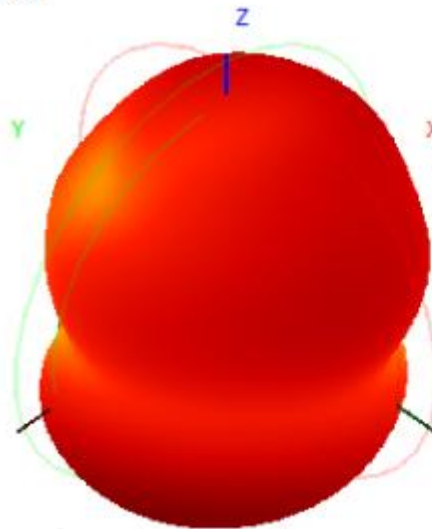

860.0MHz Total(E1-XZ), Max= 0.48dBi

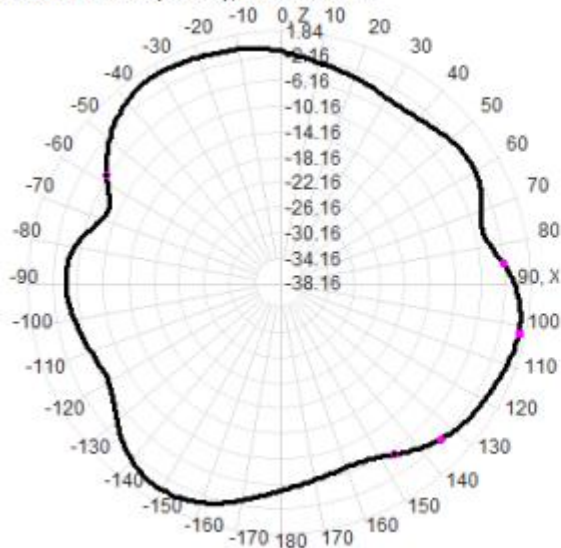

860.0MHz Total(E2-YZ), Max= 0.50dBi

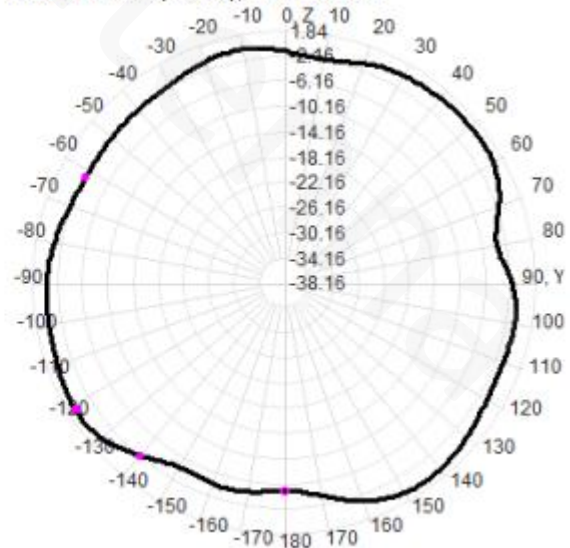

960.0MHz H+V, Eff: 64.3%

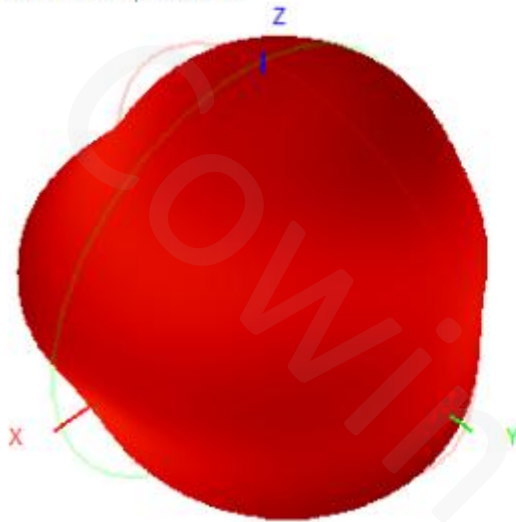

Back View

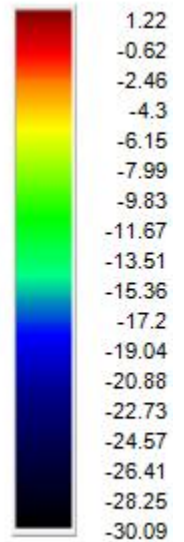
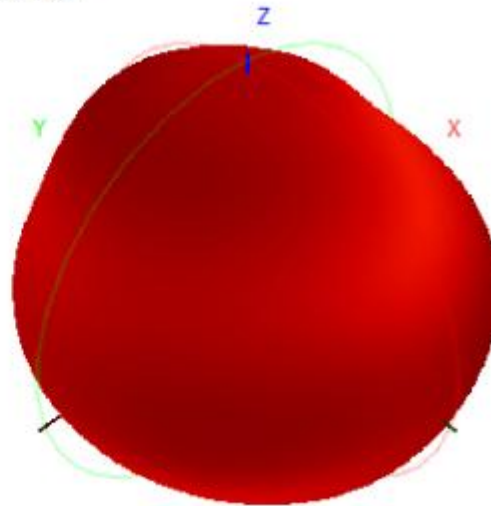

960.0MHz Total(E1-XZ), Max= 0.83dBi

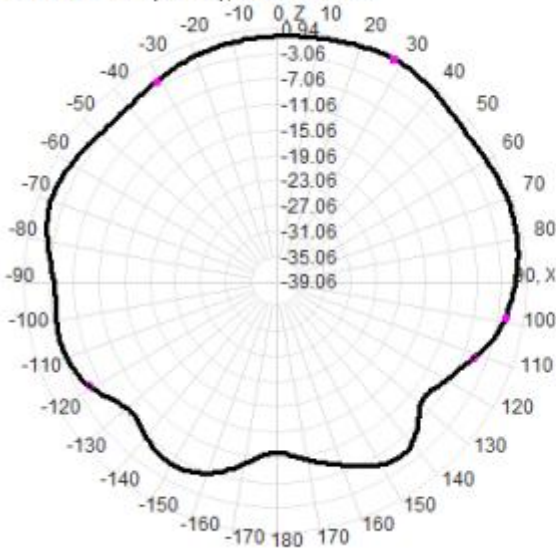

960.0MHz Total(E2-YZ), Max= 0.36dBi

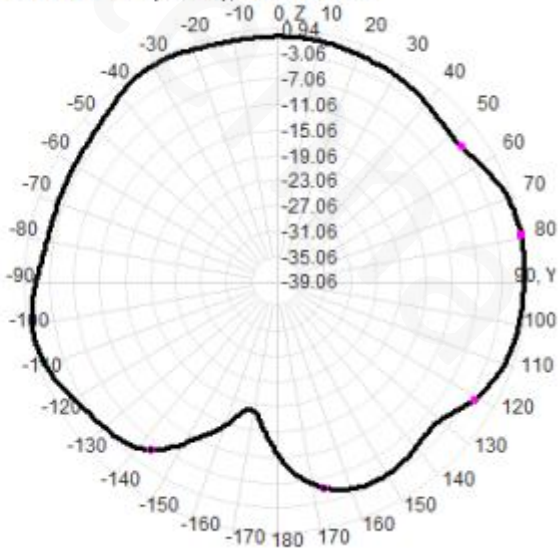

1710.0MHz H+V, Eff: 53.8%

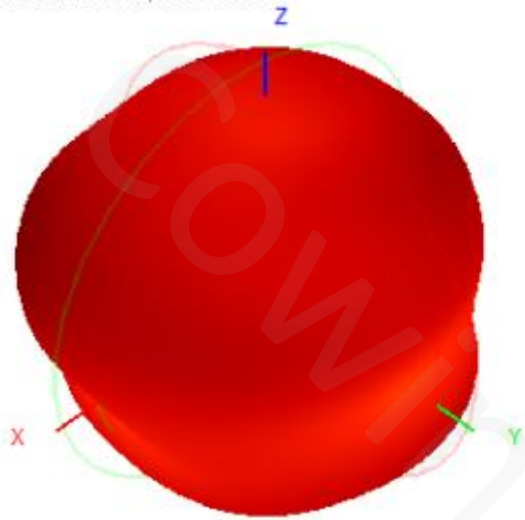

Back View

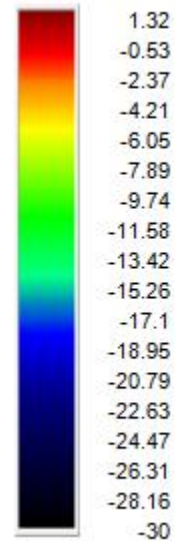
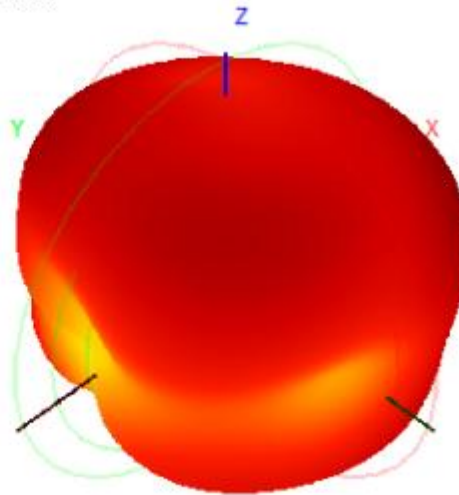

1710.0MHz Total(E1-XZ), Max= 0.02dBi

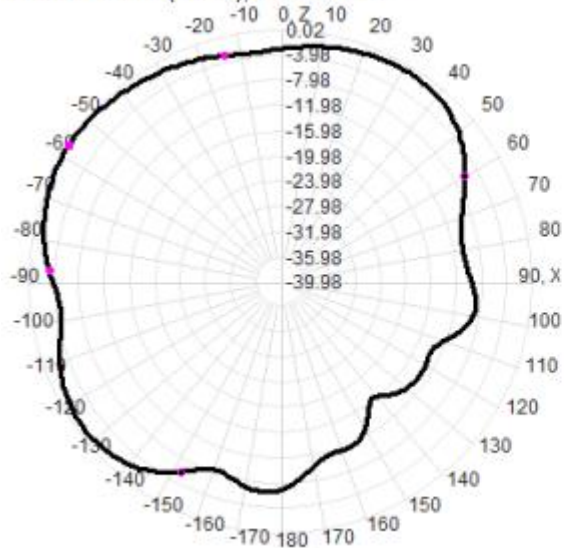

1710.0MHz Total(E2-YZ), Max= -0.49dBi

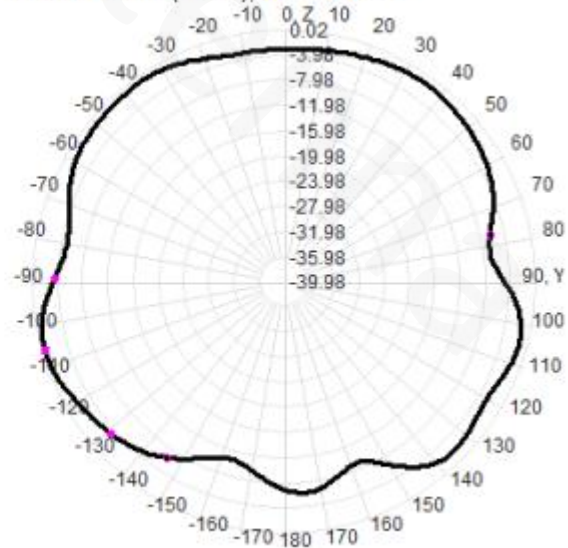

2210.0MHz H+V, Eff: 60.0%

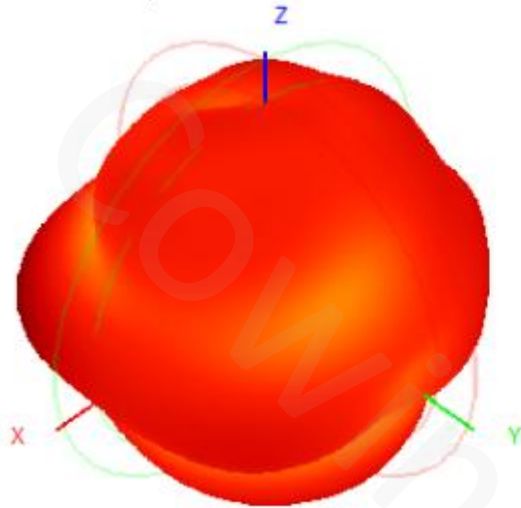

Back View

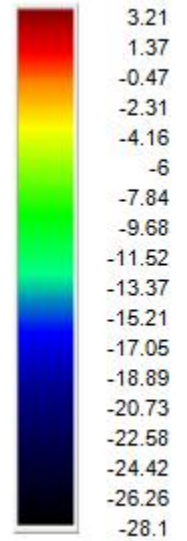
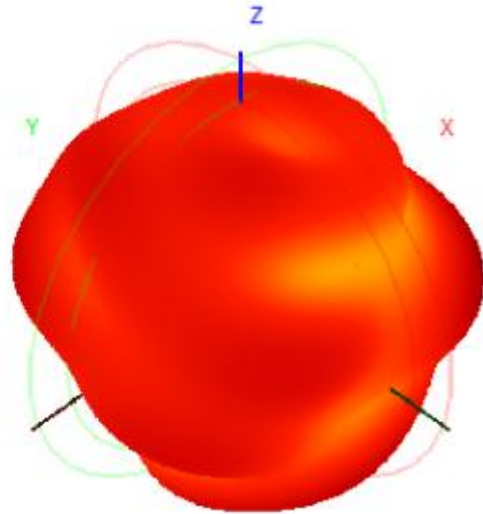

2210.0MHz Total(E1-XZ), Max=-0.39dBi

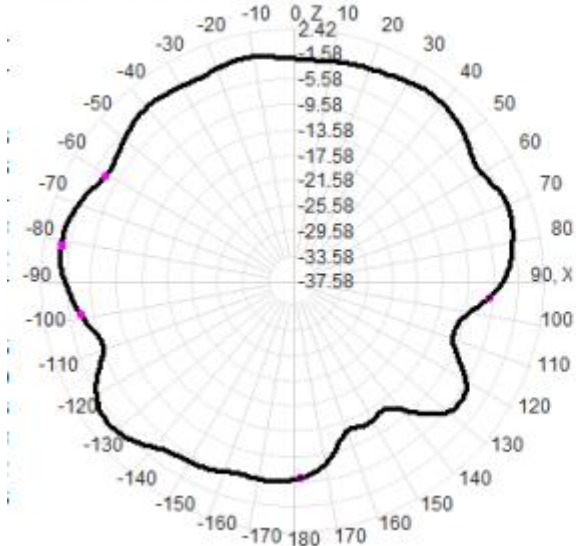

2210.0MHz Total(E2-YZ), Max= 1.72dBi

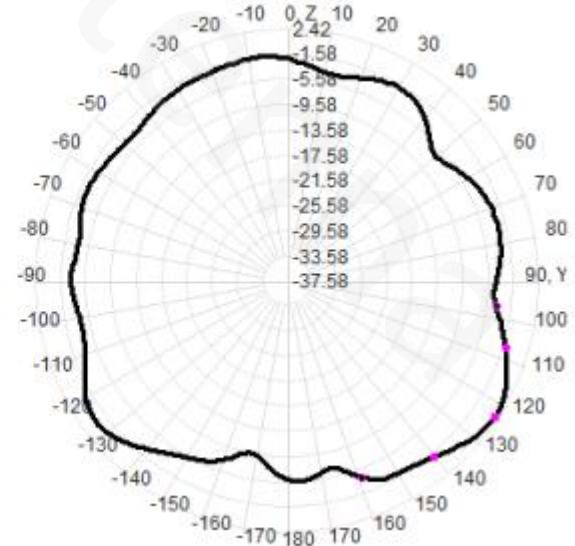

2710.0MHz H+V, Eff: 45.5%

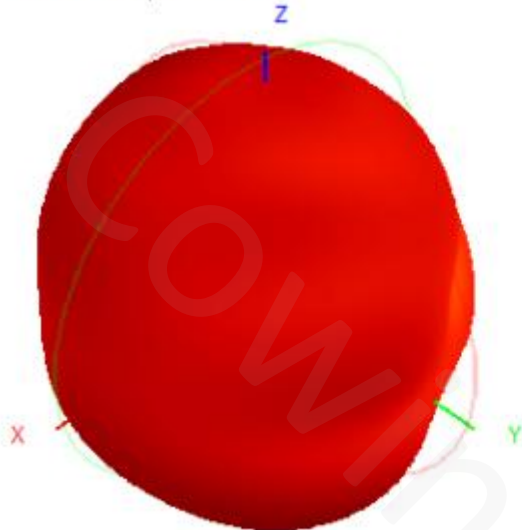

Back View

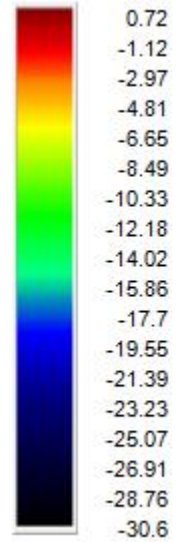
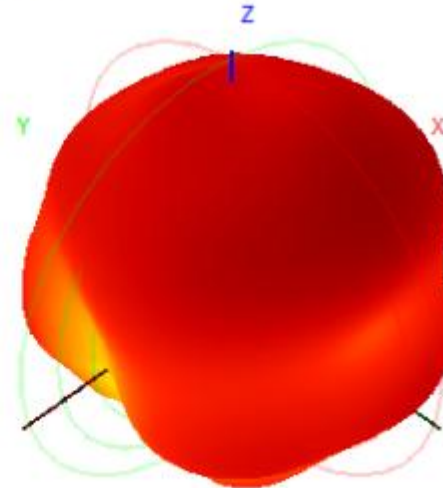

2710.0MHz Total(E1-XZ), Max= -0.33dBi

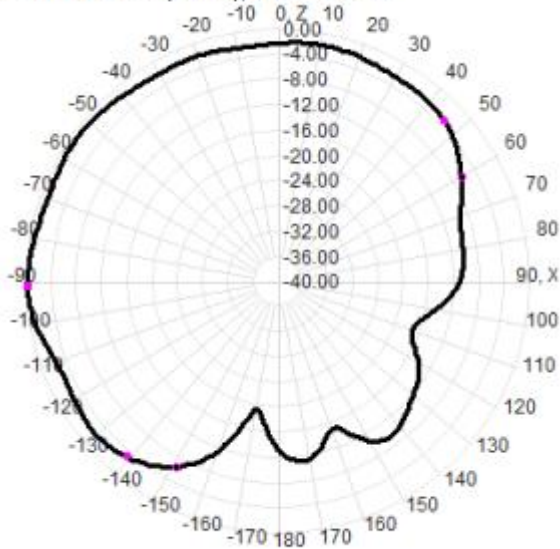

2710.0MHz Total(E2-YZ), Max= 0.00dBi

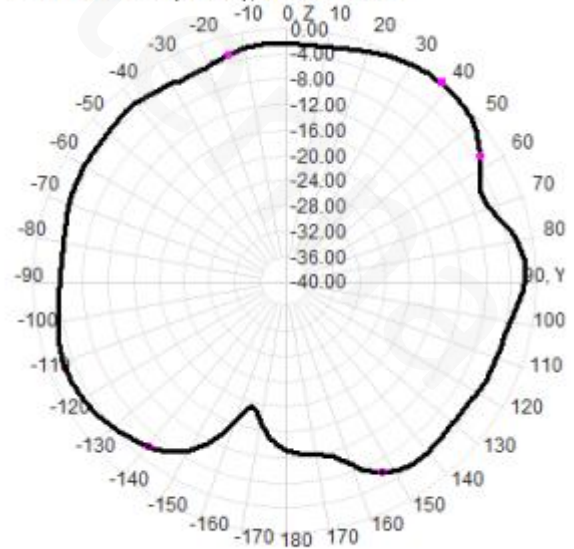

4.4 WIFI 3D&2D Radiation Patterns

2400.0MHz H+V, Eff: 55.3%

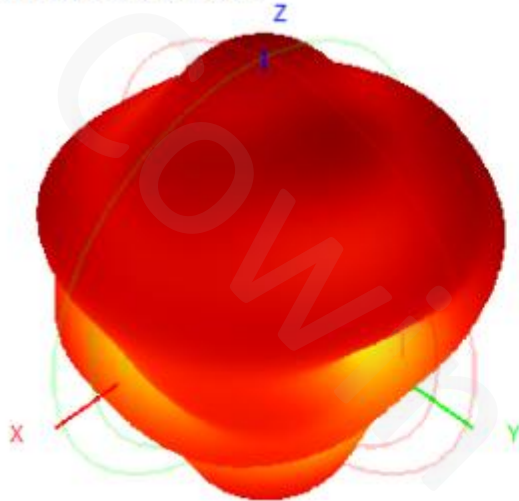

Back View

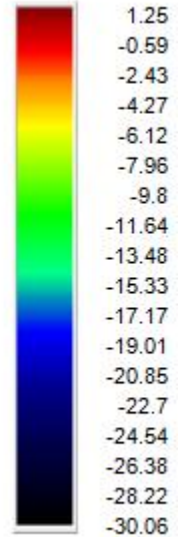
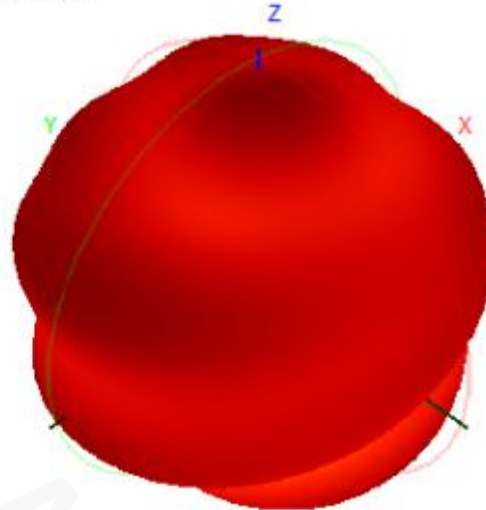

2400.0MHz Total(E1-XZ), Max= 1.12dBi

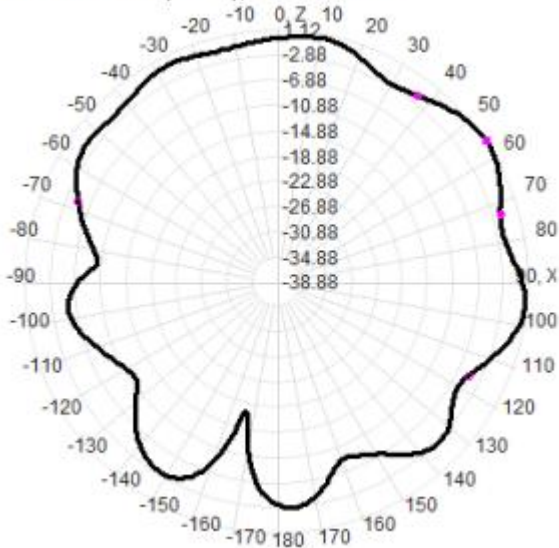

2400.0MHz Total(E2-YZ), Max= 0.77dBi

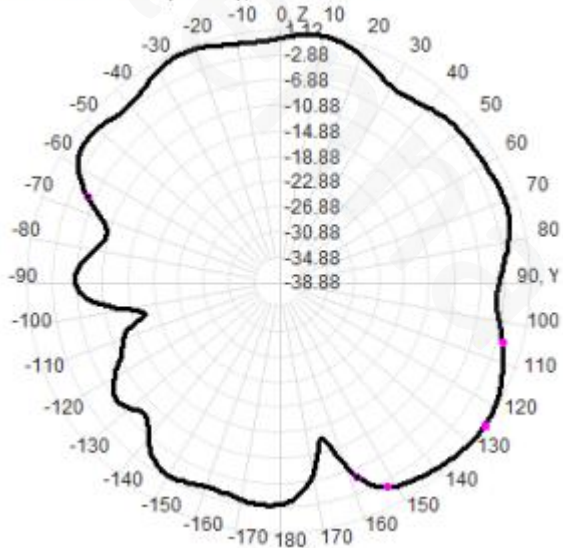

2450.0MHz H+V, Eff: 60.5%

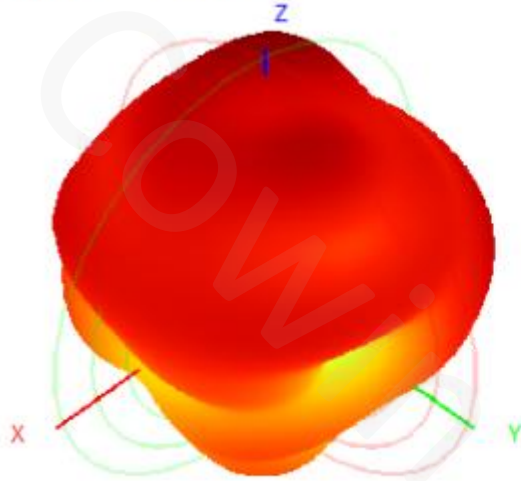

Back View

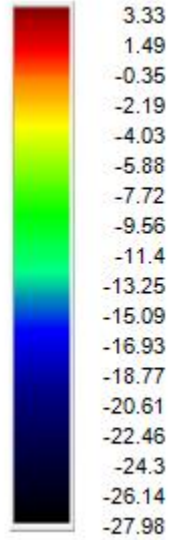
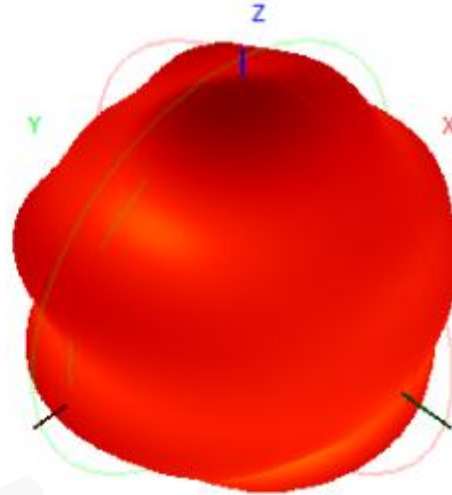

2450.0MHz Total(E1-XZ), Max= 2.60dBi

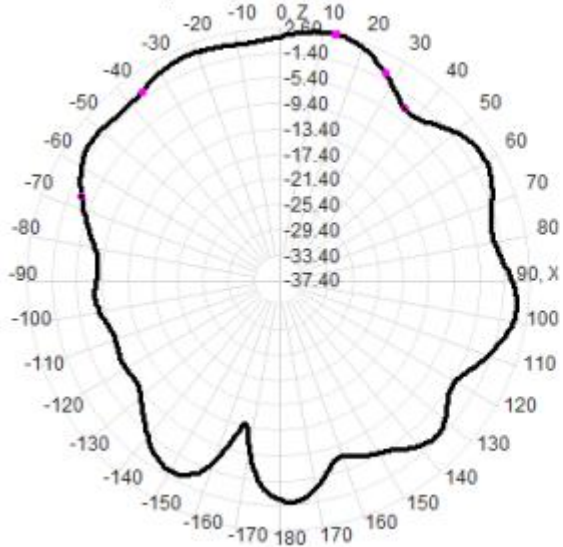

2450.0MHz Total(E2-YZ), Max= 2.50dBi

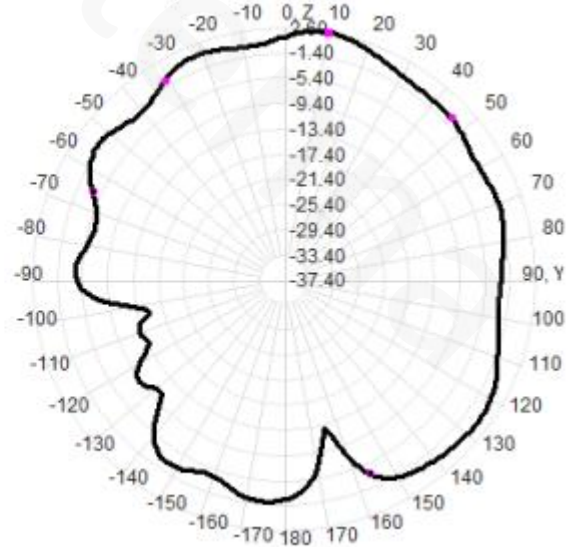

2500.0MHz H+V, Eff: 61.7%

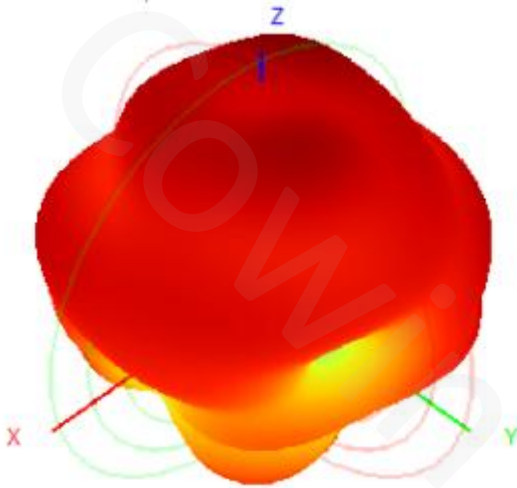

Back View

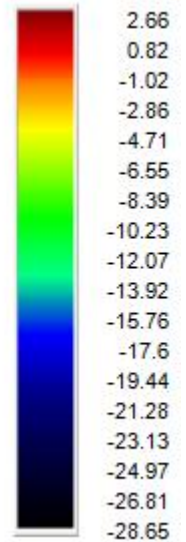
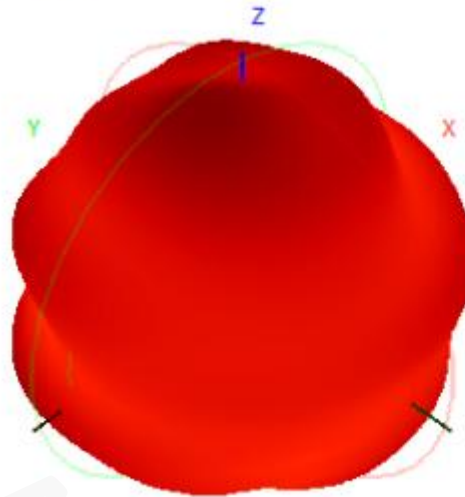

2500.0MHz Total(E1-XZ), Max= 2.40dBi

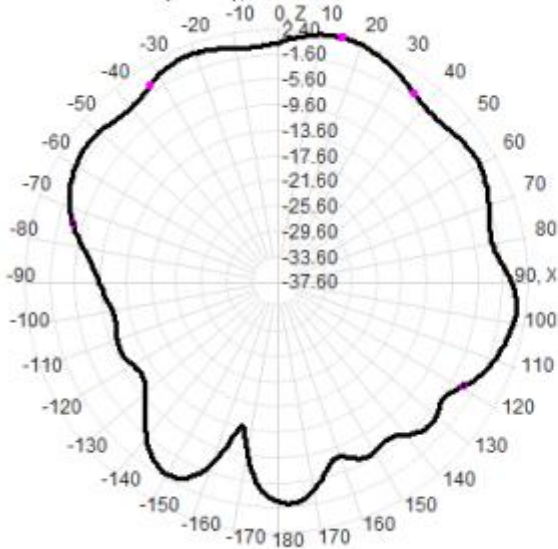

2500.0MHz Total(E2-YZ), Max= 1.09dBi

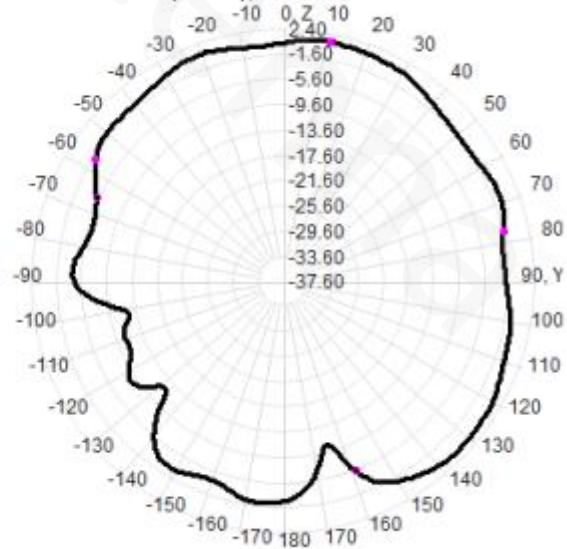

4.5 GPS 3D&2D Radiation Patterns

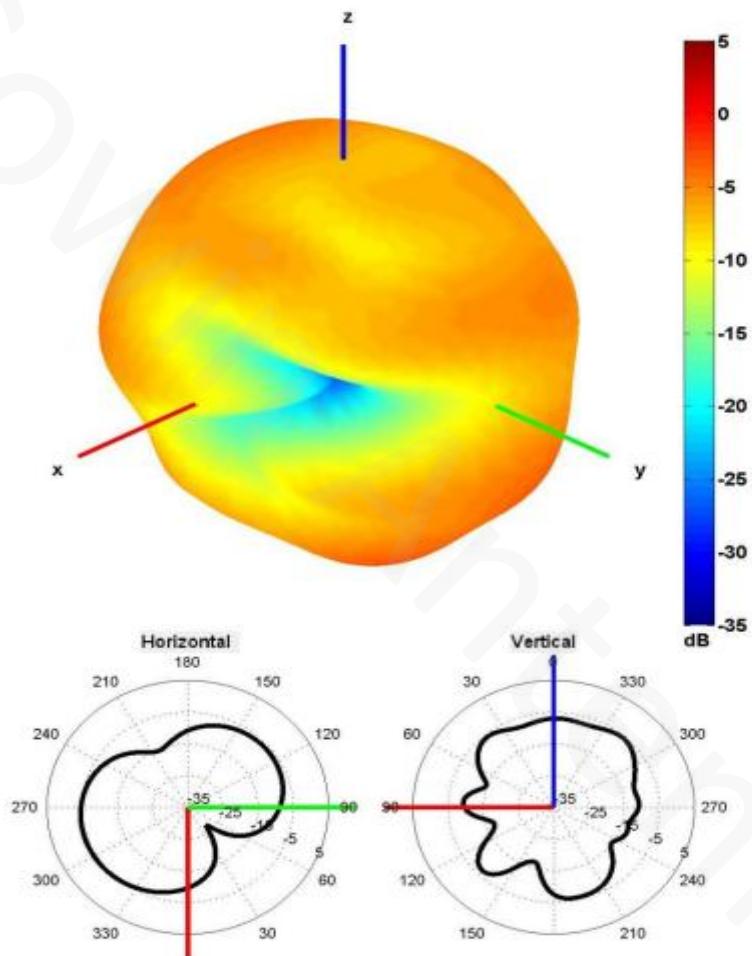

1560MHZ Radiation pattern

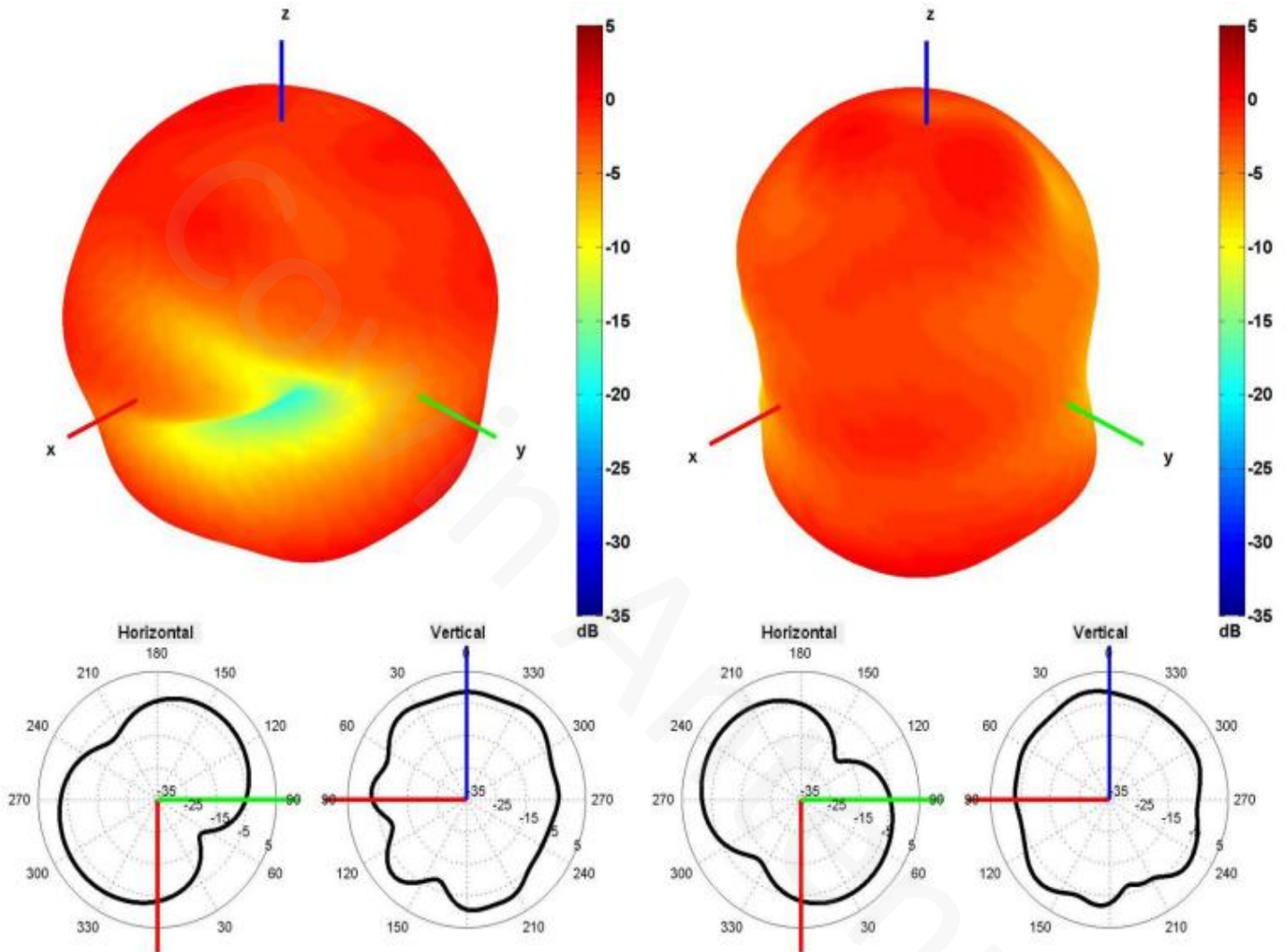

1575&1605MHZ Radiation pattern